



RIECHE TECHNOLOGY
CATALOG AND TECHNICAL PARAMETER
样本及技术参数



www.mogb-bearing.com



NINGBO MOGB BEARING CO. LTD.

Office Address: 18F Hengyuan Plaza,
Building A, NO. 1988, Belsanhuang East
Road, Cixi, Zhejiang Province.
P.C: 315300

Factory Address: NO. 218, Chaoyang
Road, Langxia Town, Yuyao, Zhejiang
Province. P.C: 315480

Tel: +86-13486457105

E-mail: nancyzhang@mogb-bearing.com

宁波摩嘉轴承有限公司

办公地址: 浙江省慈溪市北三环东路1988号恒元广场A座
18楼 邮编: 315300

工厂地址: 浙江省余姚市朗霞镇朝阳路218号 邮编: 315480

电话: +86-13486457105

邮箱: nancyzhang@mogb-bearing.com

NINGBO RIECHE TECHNOLOGY CO., LTD.
宁波锐驰科技有限公司

NINGBO MOGB BEARING CO., LTD.
宁波摩嘉轴承有限公司





制造基地/MANUFACTURING BASE

锐驰科技成立于2003年，经过多年的发展，锐驰科技于2011年投资1.6亿在浙江省余姚市建立了现代化制造基地，基地占地31000平方米，建筑面积40000平方米，引进具有国际先进水平的自动化生产连线及检测设备，公司注重5S现场管理,结合TS16949体系管理要求，实现了智能化、规模化、操作规范化，使产品在工艺、质量、性能等每个环节都得到严格的控制，为国际大市场提供大规模高品质的产品。

RIECHE TECHNOLOGY was founded in 2003, with many years developing, RIECHE invested USD26 million to build a new modern manufacturing base in Yuyao City, Zhejiang Province in 2011, The base covers about 31000 square meters, the construction area is 40000 square meters. Introduction automatic production line and inspection equipment with high advance technology in our world, Company focus on 5s site management and combined with TS16949 management system requirement, realized interlligentize and normalized, Our products guarantee the process, quality and performance controlled, we are able to apply high quality products to oversea markets.





全自动质控设备/FULL-AUTOMATION QUALITY CONTROL EQUIPMENTS

先进的生产设备是制造完美优质产品的关键，公司在规范自身生产规模和流程的同时不断与国际接轨，引进具有国际先进水平的生产设备，逐步实现生产智能化，规模化，操作规范化，使产品在工艺、质量、性能等每个环节都得到严格的控制，为国际大市场提供大规模高品质的产品。

The advanced production equipment is the key of producing high quality products, RIECHE standards the production process to go with the tide of world development, RIECHE imports international advanced equipment to achieve intelligence and scale of production, standardization of operation, it can control each link of production to ensure providing international market with high quality products.



全自动装配车间/
FULL-AUTOMATION ASSEMBLY WORKSHOP



测试与检测/TESTING AND INSPECTION





目录>>>

生产基地	01
全自动质控设备	03
全自动装配	05
测试与检测	07
目录	09
1. 滚动轴承的结构与特性	11
2. 轴承选用方法	12
3. 轴承尺寸的选择	14
4. 轴承的极限转速	16
5. 轴承外型尺寸与代号	17
6. 轴承公差	18
7. 轴承振动	21
8. 轴承的内部游隙	22
9. 轴承游隙	25
10. 轴承的配合	26
11. 轴承材料	32
12. 轴与轴承座设计	34
13. 轴承的使用	39
常用润滑脂的明细表	41
小型球轴承 微型球轴承 (公制系列) 带止动挡边	47
小型球轴承 微型球轴承 (公制系列)	49
深沟球轴承 (公制系列)	51
深沟球轴承 (英制系列)	59
深沟球轴承 (摩托车)	61
深沟球轴承 (非标系列)	63
深沟球轴承 (汽车)	65
深沟球轴承 (导轨滚轮轴承)	70

CONTENTS>>>

Production Base	01
Full-Automation Quality Control Equipments	03
Full-Automation Assembly	05
Testing and Inspection	07
Contents	09
1. Structure and Characteristics of Rolling Bearings	11
2. Bearing selection Methods	12
3. Selection of Bearing Dimensions	14
4. Bearing Limiting Speed	16
5. Outline Dimensions and Codes of Bearings	17
6. Bearing Tolerance	18
7. Bearing Vibration	21
8. Bearing Internal Clearances	22
9. Bearing Clearances	25
10. Bearing Fits	26
11. Bearing Materials	32
12. Design of Surrounding Structure	34
13. Bearing Handling	39
A Detail List of The Commonly-Used Grease	41
Miniature Ball Bearings(Metric Series)With Flange	47
Miniature Ball Bearings(Metric Series)	49
Deep Groove Ball Bearing(Metric System Series)	51
Deep Groove Ball Bearing(Inch System Series)	59
Deep Groove Ball Bearing(For Motorcycle)	61
Deep Groove Ball Bearing(Special Bearing)	63
Deep Groove Ball Bearing(For Automofive)	65
Deep Groove Ball Bearing (Guide roller bearing)	70

1. 滚动轴承的结构特性

1.1 结构与分类

滚动轴承（以下简称轴承）一般由套圈、滚动体及保持架组成。按滚动体的种类，分为球轴承和滚子轴承。

具有代表结构的轴承结构见图1.1所示。

1.2 结构与特征

滚动轴承具有以下特点：

- (1) 已实现标准化、规格化，具有互换性；
- (2) 一般可以同时承受径向负荷和轴向负荷；
- (3) 较低的摩擦转矩；
- (4) 较低的振动和噪声；
- (5) 适用于高、低温条件下使用；
- (6) 适用于高速条件下使用。

单列深沟球轴承，是滚动轴承中应用最广的结构。轴承可以同时承受径向负荷和轴向负荷，适用于高速旋转、低噪声等使用场合。

这种轴承，除开式外，还有带钢板防尘盖和橡胶密封圈的轴承。例：608ZZ、608-2RS。

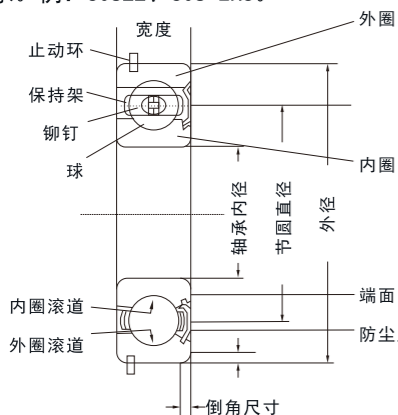


图1.1 单列深沟球轴承

1. STRUCTURE AND CHARACTERISTICS OF ROLLING BEARINGS

1.1 Structure and Classification

Rolling bearing (below abbreviated as bearing) is commonly composed of two rings, rolling elements and cage. According to the rolling element's type, it is divided into ball bearing and roller bearing.

Please refer to Fig.1.1 that shows a typical bearing structure.

1.2 Structure and Features

The rolling bearing has the following advantages:

- (1) With the advancement of world wide standardization, Rolling bearings are internationally available and interchangeable.
- (2) Commonly it can bear radial load and axial load simultaneously or independently.
- (3) It's characterized by lower friction torque.
- (4) It possesses lower vibration and noise level.
- (5) It is applicable for use in high and low temperature.
- (6) It is fit for use in high speed condition.

Single row deep groove ball bearing is the structure with the widest application in rolling bearings. The bearing can simultaneously bear radial load and axial load. It is fit for use in the occasions such as high-speed rotation, low noise etc.

Apart from open type, it also has the bearing with shields and the bearing with rubber seals. e.g.608ZZ, 608-2RS.

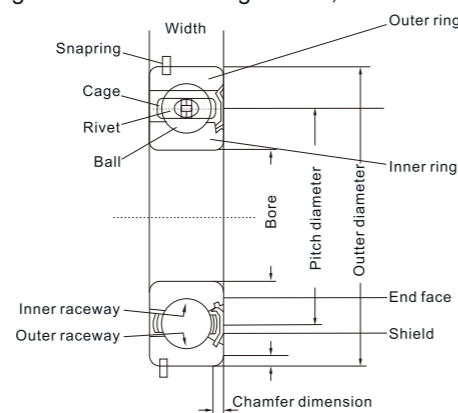


Fig.1.1 Single Row Deep G roove Ball Bearing

2 轴承选用方法

使用滚动轴承的各种机械装置、仪器等的市场要求性能日趋严格，对于轴承所要求的条件、性能也日趋多样化。

为了能从为数众多的结构、尺寸中，选择最适合的轴承，需要从各种角度进行研究。

在选择轴承时，首先，考虑作为轴系的轴承排列、安装、拆卸的难易度、轴承所允许的空间、尺寸及轴承的市场性及经济性等，来决定轴承结构。

其次，一方面要考虑使用轴承的各种机械的设计寿命和轴承的寿命极限，另一方面也要考虑轴承的尺寸。

在选择轴承时，通常只考虑轴承的疲劳寿命，而实际上由润滑脂老化引起的润滑脂寿命、磨损、噪声等也需要进行考虑研究。

再者，根据不同的用途，有必要对精度、游隙、保持架结构、润滑脂等提出要求，进行轴承的特殊设计。

但是，轴承的选择并没有一定的顺序、规则，优先应考虑的是轴承的使用条件、性能及一些相关的要求。在选择用于新机械、特殊使用条件、特殊环境条件的轴承时，请与MOGB联系。

作为一般选择轴承的参考例子，其过程如图2.1所示：

图2.1 轴承选用方法

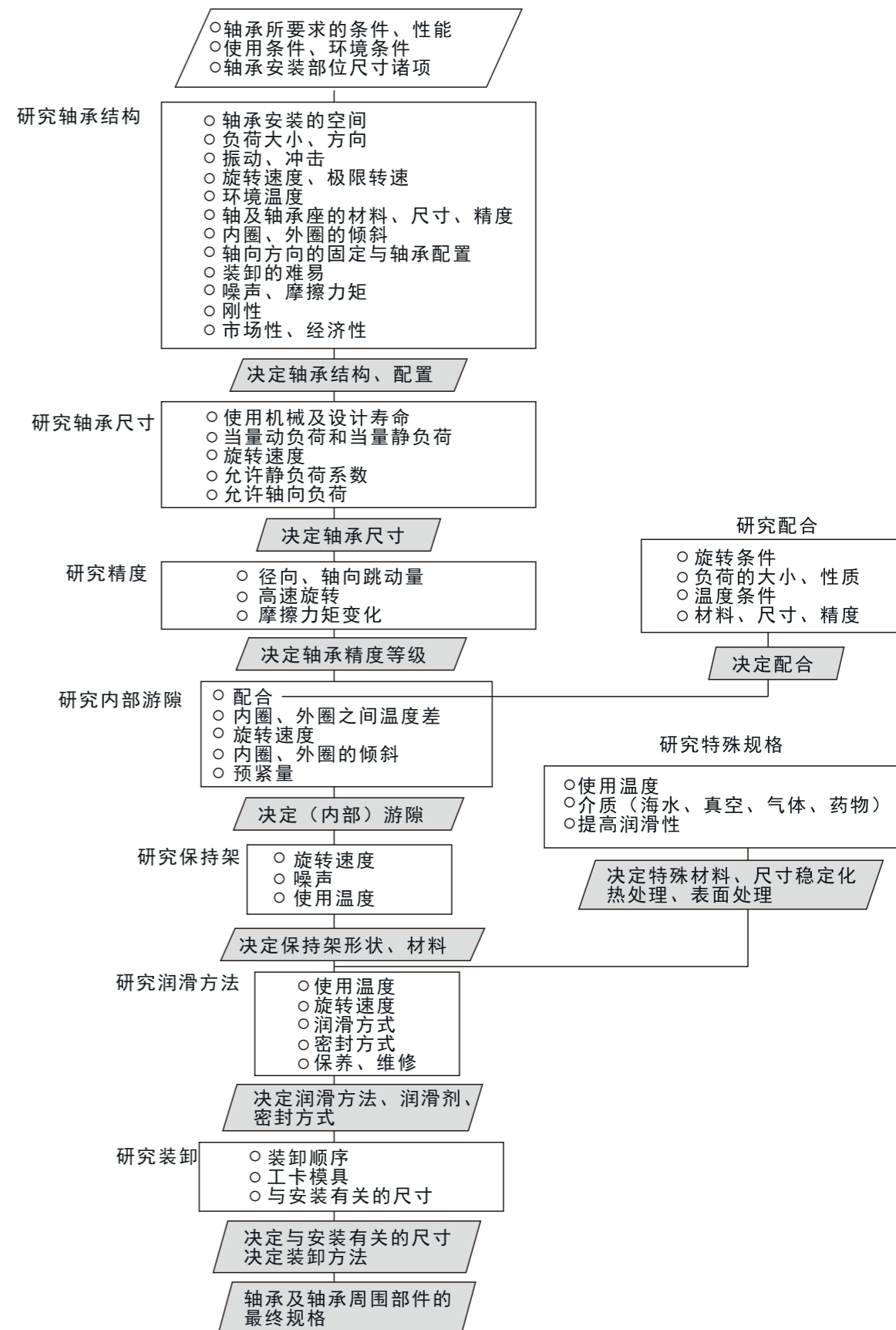
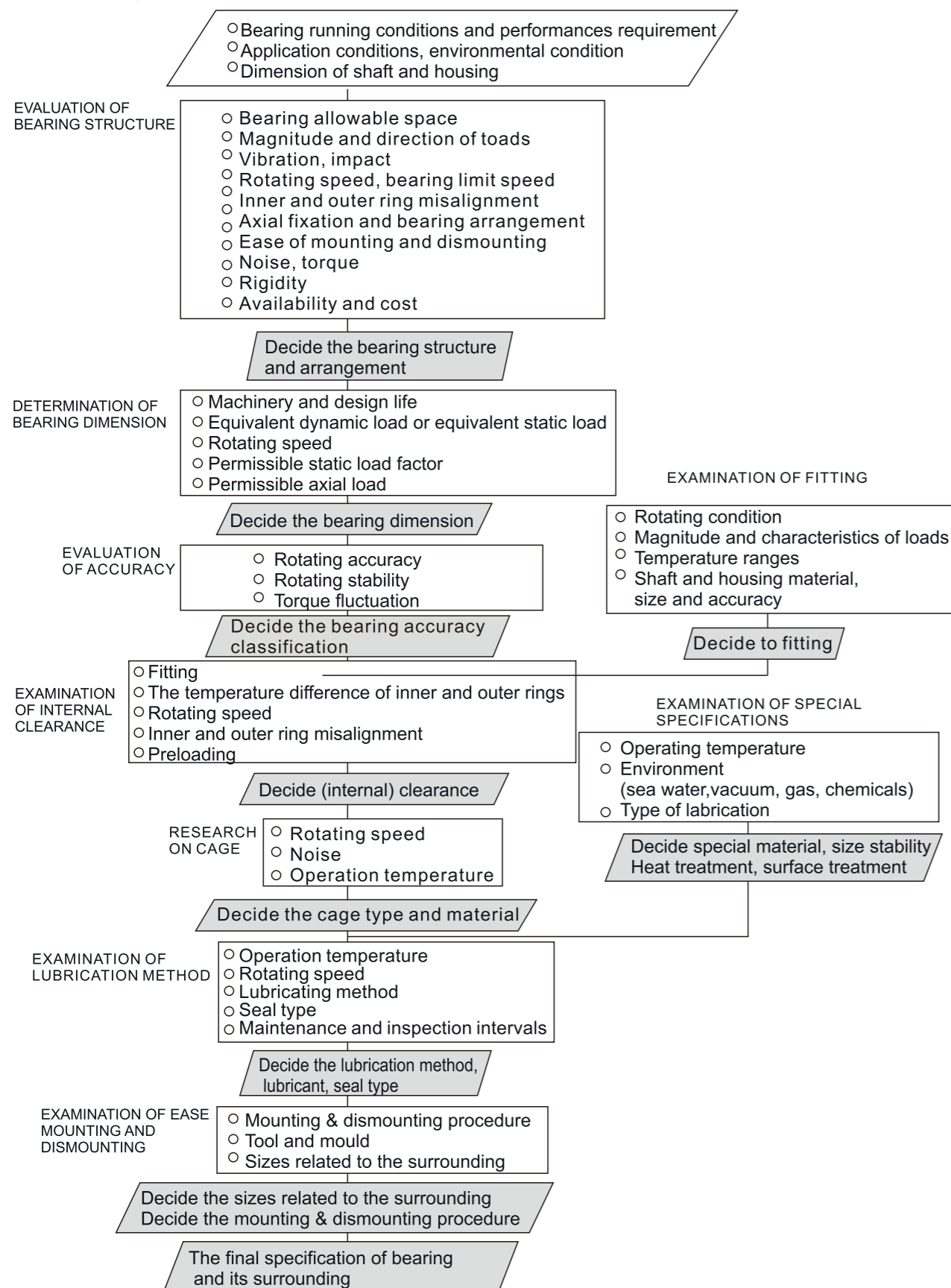


Table 2.1 Bearing Selection Flow Chart



3. 轴承尺寸的选择

3.1 轴承的寿命

轴承经过一定时间运转后，精度下降，噪声、振动增大，润滑脂老化，滚动面疲劳剥落，使轴承不能使用，这种轴承的使用时间是广义的轴承寿命。分别称为：精度寿命、噪声寿命、润滑脂寿命、滚动疲劳寿命等。

3.1.1 额定疲劳寿命

额定疲劳寿命，是指将同一型号的轴承在相同条件下运转，可靠性为90%的轴承运转总次数。在旋转速度一定的情况下，一般用总运转时间来表示额定疲劳寿命。

3.2 基本额定动负荷

3.2.1 基本额定动负荷为作用于外圈静止的轴承上的恒定的负荷。在这种负荷下，额定疲劳寿命为100万转。

3.2.2 球轴承基本额定寿命

$$(总旋转数) L_{10} = (c/p)^3 \dots\dots 3.1$$

表示基本额定动负荷、当量动负荷及基本额定寿命之间的关系。

$$(时间) L_{10h} = (10^6/60n) \cdot (c/p)^3 \dots\dots 3.2$$

轴承以恒速旋转时，用时间表示寿命更为便，如式3.2所示。

式中：

L_{10} - 基本额定寿命 (10⁶转)；

L_{10h} - 基本额定寿命，以小时表示；

P - 当量动负荷，N；

C - 基本额定动负荷，N；

n - 转速，rpm。

3.2.3 根据温度修正基本额定动负荷

高温下使用的滚动轴承，轴承硬度下降，疲劳寿命比常温使用时降低。基本额定动负荷相应地降低。按照下式修正。

$$C_t = f_t \times C \dots\dots 3.3$$

式中：

C_t - 根据温度修正的基本额定动负荷；

f_t - 温度系数 (表3.1)；

C - 基本额定动负荷。

在120℃以上高温下使用的轴承，一般要进行尺寸稳定处理。

表3.1

轴承温度℃	125	150	175	200	250
温度系数ft	1.00	1.00	0.95	0.90	0.75

代号	SO	S1	S2
温度	200℃	250℃	300℃
套圈硬度HRC	59~64	57~62	55~59

表3.2可靠性系数a₁的值

可靠性%	90	95	96	97	98	99
a ₁	1.00	0.62	0.53	0.44	0.33	0.21

如果轴承没有倾斜，并使用粘度高的润滑油(a₂, a₃)值可设为2。

3. SELECTION OF BEARING SIZE

3.1 Bearing Life

After certain period of the bearing running, the bearings accuracy will be lowered, and the noise and vibration will be increased with lubricating grease ageing and the rolling surface flaking because of fatigue. Therefore the bearing cannot be used any more. The service life of this kind of bearing is called the bearing life in a broad sense. They are respectively named as accuracy life, noise life, lubricating grease life, rolling fatigue life etc.

3.1.1 Fatigue life rating

Fatigue life rating refers to total revolutions of bearing running with 90% reliability for seemingly identical bearings under the same operating conditions. Under a certain rotating speed, it usually indicates the fatigue life rating by counting the total running period. Usually define the fatigue life as bearing life.

3.2 Basic Dynamic Load Rating

3.2.1 Basic dynamic load rating

Applying the constant load to the stationary outer ring, the fatigue life rating is 1 million revolutions. The load is defined as basic dynamic load rating

3.2.2 Basic rating life of ball bearing

$$(Total revolutions) L_{10} = (C/p)^3 \dots\dots 3.1$$

It indicates the relations among basic dynamic load rating, equivalent dynamic load and basic life ratings.

$$(Time) L_{10h} = 10^6/60n(C/p)^3 \dots\dots 3.2$$

It is more convenient to indicate the life by time when the bearing is rotated at a constant speed, as it is listed in formula 3.2.

In which,

L_{10} - the basic rating life;

L_{10h} - the basic rating life (10⁶revolutions)；

P - the equivalent dynamic load, N；

C - the basic dynamic load rating, N；

n - the rotating speed, rpm.

3.2.3 Modified the basic dynamic load rating according to the specific temperature

When the rolling bearings have been applied under high temperature conditions, the bearing hardness will be reduced, and the fatigue life will be lowered than that for application in normal temperature. Therefore the basic dynamic load rating should be assessed a little smaller correspondingly.

$$C_t = f_t \times C \dots\dots 3.3$$

In which:

C_t - the basic dynamic load according to the temperature correction;

f_t - the temperature coefficient (Table 3.1);

c - the basic dynamic load rating.

When the bearing is applied under high temperatures above 120℃, it should commonly be implemented with size stability treatment.

Table 3.1

Bearing temperature℃	125	150	175	200	250
Temperature coefficient ft	1.00	1.00	0.95	0.90	0.75

Code	SO	S1	S2
Temperature℃	200℃	250℃	300℃
Ring hardnessHRC	59~64	57~62	55~59

Table3.2Reliability Factor a₁Value

Reliability%	90	95	96	97	98	99
a ₁	1.00	0.62	0.53	0.44	0.33	0.21

If the bearing is not misalignment, and it uses the lubricating oil with high viscosity, 2 can be set to (a₂ x a₃).

3.2.4修正额定疲劳寿命

球轴承额定疲劳寿命的基本公式,

$$L_{10} = (c/p)^3 \quad \dots\dots 3.4$$

L_{10} 是可靠性为90%的额定疲劳寿命。随着轴承用钢材的改进, 疲劳寿命也存延长。可使用以下修正系数, 修改额定疲劳寿命。

$$L_n = a_1 a_2 a_3 L_{10} \quad \dots\dots 3.5$$

L_n —考虑了可靠性、材料改进、润滑条件后的疲劳寿命;
 L_{10} —可靠性90%的额定疲劳寿命;
 a_1 —可靠系数
 a_2 —轴承材料系数;
 a_3 —使用条件系数。

可靠性为90%以上时 a_1 值见表3.2。

3.3轴承负荷的计算

3.3.1 负荷系数

径向负荷、轴向负荷, 虽然可以计算出来, 由手机械振动冲击, 实际作用于轴承的负荷往往要比计算值大, 负荷值可以用以下公式修正:

$$F_r = f_w \cdot F_{rc} \quad \dots\dots 3.6$$

$$F_a = f_w \cdot F_{ac} \quad \dots\dots 3.7$$

其中:

F_r, F_a —作用于轴承的负荷, N

F_{rc}, F_{ac} —理论上计算负荷, N

负荷系数 f_w , 见表3.3

表3.3 负荷系数 f_w

运转条件	使用场所例	f_w
无冲击圆滑运转	电机、机床空调机	1~1.2
普通运转	鼓风机、压缩机、电梯起重机、造纸机械	1.2~1.5
伴有振动、冲击的运转	建筑机械, 碎石机(砂轮), 振动筛、压延机	1.5~3

3.4当量动负荷

轴承大多承受径向负荷与轴向负荷的联合负荷, 并且负荷大小、方向也会随时间发生变化。因此要将实际负荷换算成通过轴承中心, 且大小和方向一定的当量负荷来进行寿命计算, 轴承在当量负荷下具有与实际负荷相同的寿命。

3.4.1当量动负荷的计算

径向轴承的当量动负荷, 可按以下公式求出。

$$P = X F_r + Y F_a \quad \dots\dots 3.8$$

其中:

P —当量动负荷, N;

F_r —径向负荷, N;

F_a —轴向负荷, N;

X —径向负荷系数;

Y —轴向负荷系数。

3.2.4 Modified fatigue life rating

The basic formula of the fatigue life rating of ball bearing

$$L_{10} = (C/P)^3 \quad \dots\dots 3.4$$

L_{10} is fatigue life with rating 90% reliability. With the improvement of the rolling bearing steel adopted by the bearings, the fatigue life will be extended accordingly. It can use the following modification coefficient to modify the rating fatigue life rating.

$$L_n = a_1 a_2 a_3 L_{10} \quad \dots\dots 3.5$$

L_n —indicates the fatigue life with the considerations of the reliability, material improvement, lubricating condition;
 L_{10} —the fatigue life rating with 90% reliability;
 a_1 —the reliability factor;
 a_2 —the bearing material factor;
 a_3 —the running condition factor.
 Please refer to Table 3.2 for a_1 , with higher than 90% of the reliability.

3.3 Calculation of Bearing Load

3.3.1 Load factor

Though it can calculate the radial load and axial load, the result is not exact. The load which actually affects the bearing is usually larger than the calculated value because of the mechanical vibration impact. The load value can be worked out according to the following formula:

$$F_r = f_w \cdot F_{rc} \quad \dots\dots 3.6$$

$$F_a = f_w \cdot F_{ac} \quad \dots\dots 3.7$$

In which,

F_r, F_a - the load (N) {kgf} which actually applies the bearing.

F_{rc}, F_{ac} - the theoretically calculated load, N

Please refer to Table 3.3 for the load factor of f_w .

Table 3.3 Load Factor f_w

Running condition	Typical applicationj	f_w
Smooth running free of impact	Motor, machine tool, air-conditioner	1~1.2
Ordinary running	Air blower, compressor, crane, paper-making machinery	1.2~1.5
Running with vibration, impact	Construction machinery, Crusher, Vibrating screen, Rolling mill	1.5~3

3.4 Equivalent Dynamic Load

Most of the bearings undertake the synthetic load of radial loads and axial loads. In addition, such loads usually fluctuate in both magnitude and direction. Therefore we should convert the actual load to the equivalent load with defined amplitude and direction which passes through the bearing center. The bearing has the same life as the actual load under conditions of the equivalent load.

3.4.1 Calculation of equivalent dynamic load

The equivalent dynamic load of radial bearing can be calculated according to the following formula :

$$P = X F_r + Y F_a \quad \dots\dots 3.8$$

In which

P —the equivalent dynamic load, N;

F_r —the radial load, N;

F_a —the axial load, N;

X —the radial load factor;

Y —the axial load factor.

3.5基本额定静负荷与当量静负荷。

3.5.1基本额定静负荷

基本额定静负荷 C_0 , 是在承受最大应力的滚动体与滚道接触的接触应力为下列计算值时的静负荷。

球轴承4200MPa

承受这种接触应力的接触区, 滚动体的永久变形量与滚道的永久变形量之和, 大约是滚动体直径的0.0001倍。

3.5.2当量静负荷

轴承静止或转速极低时, 在当量负荷作用下, 承受最大负荷的滚动体与滚道的接触应力与实际负荷条件下的接触应力相等。

径向轴承的当量静负荷, 用下列二个公式计算, 并取其中大的数值。

$$P_0 = X_0 F_r + Y_0 F_a$$

$$P_0 = F_r$$

其中:

P_0 —当量静负荷, N;

F_r —径向负荷, N;

F_a —轴向负荷, N;

X_0 —静径向负荷系数;

Y_0 —静轴向负荷系数;

3.5 Basic Static Load Rating and Equivalent Static Load

3.5.1 Basic static load rating

Basic static load rating (C_0) is a static load that produces the following contacting stress at the center of contact area between the bearing raceway and the rolling element.

In the contact area, which bears such kind of contact stress, the sum total of the permanent deformation volume from the ball and raceway groove is about 0.0001 times of rolling element diameter.

3.5.2 Equivalent static load

When the bearing is stationary (including very low rotation or oscillation), under the equivalent static load the contact stress of rolling element and raceway which bear the maximum load is the same as that under actual load conditions.

The equivalent static load of radial bearing will adopt the larger value which results from the following two formulas.

$$P_0 = X_0 F_r + Y_0 F_a$$

$$P_0 = F_r$$

In which:

P_0 —the equivalent static load, N;

F_r —the radial load, N;

F_a —the axial load, N;

X_0 —the static radial load coefficient;

Y_0 —the static axial load coefficient.

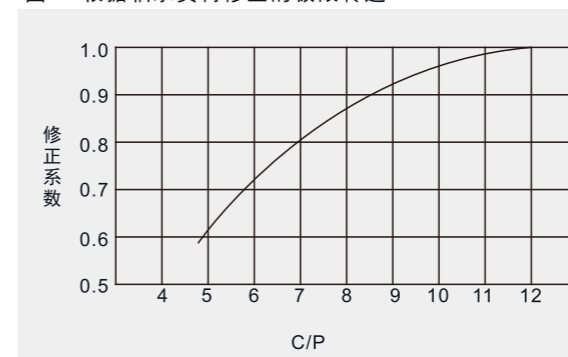
4 轴承的极限转速

滚动轴承有一定的旋转速度极限。轴承尺寸表中列出轴承脂润滑及油润滑时的极限转速。这些数值是标准设计轴承在普通负荷条件下所允许的旋转速度。当轴承旋转速度达到极限转速70%时, 需选择高速性能优良的润滑脂、润滑油。

4.1 极限转速的修正

当轴承负荷 P , 超过基本额定负荷8%, 或轴向负荷 F_a 超过径向负荷 F_r 20%的使用条件下, 极限转速要乘以修正系数(图4.1, 4.2)。

图4.1 根据轴承负荷修正的极限转速



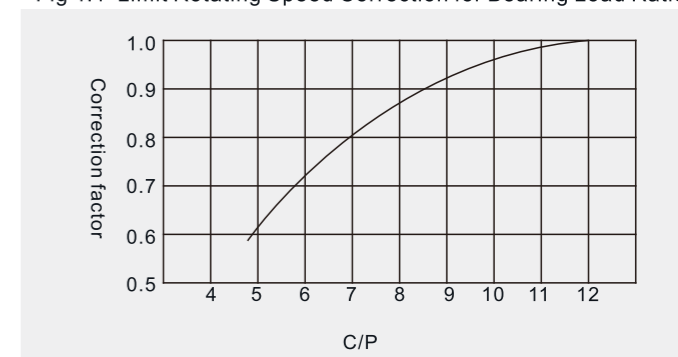
4 BEARING LIMITING SPEED

Rolling bearing has a defined rotating speed limit. The limiting speeds of bearing with grease lubrication and oil lubrication are listed in the Bearing Dimension Size Table. It is an allowable rotating speed of the bearings with standard design under ordinary load conditions. When the bearing rotating speed is more than 70% of the limit rotating speed, it should choose the superior lubricating grease or oil with high speed and superior performance.

4.1 Correction of Limiting Speed

When the bearing load exceeds 8% of the basic load rating or the axial load F_a is higher than 20% of the radial load F_r , the limiting speed should times the modification factor. See Table 4.1, 4.2.

Fig 4.1 Limit Rotating Speed Correction for Bearing Load Ratio



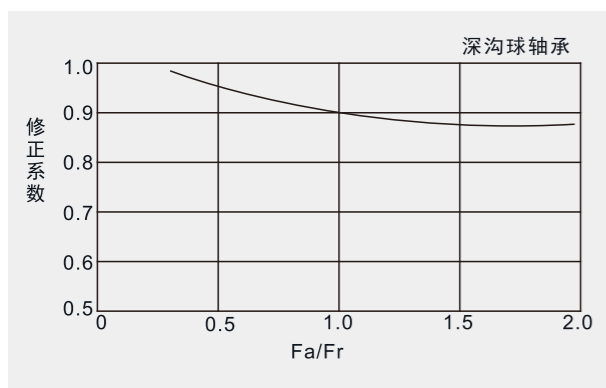


图4.2 合成负荷下极限转速的修正

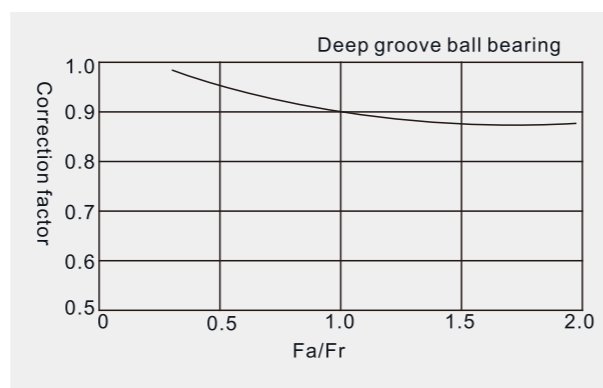


Fig 4.2 Limiting Speed Correction for Combined Radial and Axial Loads

5. 轴承的外形尺寸与代号

5.1 外形尺寸

滚动轴承的外形尺寸，如图5.1所示。

包括轴承内径 d ，轴承外径 D ，轴承宽度 B ，倒角尺寸 r 等。在国家标准(GB/T 273.3-1999)中，对全部外形尺寸作了规定

外形尺寸表中，与内径代号、内径尺寸相对应的其他尺寸，则按直径系列及尺寸系列的对应尺寸表示。

直径系列是指相对标准轴承内径的阶梯式的轴承外径系列。

尺寸系列是指宽度和直径系列的组合。

5.2 轴承代号

滚动轴承的代号，是表示轴承结构、外形尺寸、旋转精度、内部游隙、规格的名称。由基本代号和辅助代号组成(例1)、(例2)。

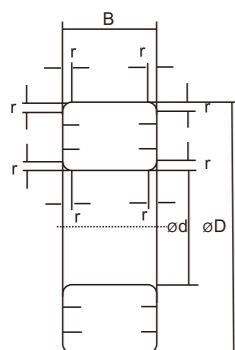


图5.1 向心球轴承向心滚子轴承

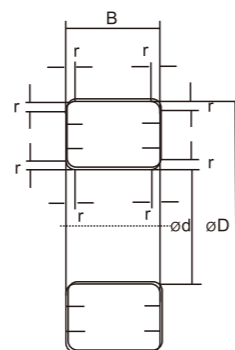


Fig 5.1 Radial Ball Bearing Radial Roller Bearing

5. OUTLINE DIMENSION AND CODE OF BEARINGS

5.1 Outline Dimension

ease refer to Fig 5.1 for the Outline dimension of rolling bearing.

It mainly has bearing bore diameter (d), bearing outside diameter (D), bearing width (B), and chamfer dimension (r) etc. All the Outline dimensions have been standardized in the National Standard of GB/T273.3-1999.

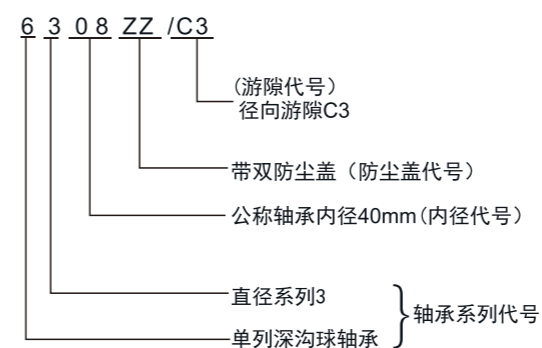
In the Outline dimension table, other dimensions which are relevant to bore diameter code, and bore dimension will be shown according to the diameter series and dimension series.

Diameter series refers to the outside diameter of bearing series comparing with the bore diameter of standard bearing.

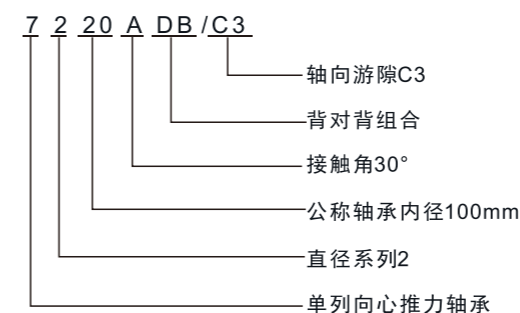
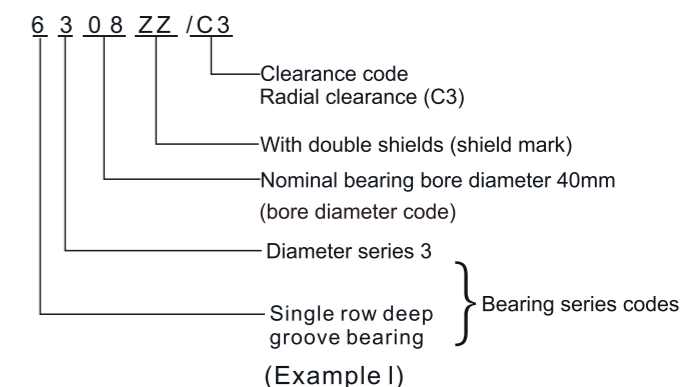
Dimension series refers to the combination between width and diameter series.

5.2 Bearing Codes

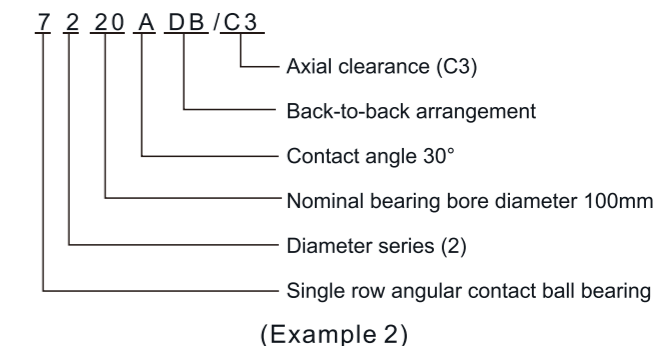
Rolling bearing code shows the bearing's structure, boundary dimension, rotating accuracy, internal clearance, and specification. It is composed of the basic and auxiliary codes. See example I, 2.



例1



例2



6. 轴承公差

滚动轴承外形尺寸的公差、公差值及旋转精度，在国家标准GB307.1中有规定。这些公差和ISO、JIS标准对照如下：

表6.1

GB/T307.1	标准公差等级				
	P0	P6	P5	P4	P2
ISO 492	Normal Class	Class6	Class5	Class4	Class2
JIS B 1514	JIS 0级	JIS 6级	JIS 5级	JIS 4级	JIS 2级
AFBMA STD.20	ABEC1	ABEC3	ABEC5	ABEC7	ABEC9

6. BEARING TOLERANCE

The rolling bearing boundary dimensions, tolerance, rotating precision are stipulated in the National Standard of GB307.1. The following is a comparison table among those tolerance and ISO, JIS Standards:

Table 6.1

GB/T307.1	Standard tolerance grades				
	P0	P6	P5	P4	P2
ISO 492	Normal Class	Class6	Class5	Class4	Class2
JIS B 1514	JIS 0Grade	JIS 6Grade	JIS 5Grade	JIS 4Grade	JIS 2Grade
AFBMA STD.20	ABEC1	ABEC3	ABEC5	ABEC7	ABEC9



表6.2 P0 P6 P5 P4级尺寸公差级旋转精度-内圈
Table6.2 P0 P6 P5 P4 Classes tolerances-inner ring

公差等级 tolerances Class	公差内径 Nominal bore diameter mm		Δ _{dmp} 单一内径 平均偏差 Deviation of mean bore diameter		Δ _{ds} 单一内径 偏差 Deviation a single bore diameter		V _{dp} 单一内径变动量 Variation of single bore diameter			V _{dmp} 平均内径 变动量 Variation of mean bore diameter	Kia 内圈 径向 跳动 Runout of inner ring	Sd 端面与 孔中心的 跳动量 Axial runout of inner ring	Sia* 内圈 轴向 跳动 runout of inner ring	Δ _{BS} 内圈单一 宽度偏差 Deviation of inner ring width		V _{BS} 内圈宽度 变动量 Variation of inner ring width
	超过 Over	到 incl	上偏差 max	下偏差 max	最大 max	直径系列Diameter series	上偏差 max	下偏差 max								
					最大 max		0.1** (1.7)		2.3.4							
P0*** (ABEC-1)	0.6	2.5	-8		10	8	6	6	6	6	10	10	20	-40	12	
	2.5	10	-8		10	8	6	6	6	6	10	10	20	-120	15	
	18	30	-8		10	8	6	6	6	6	10	14	20	-120	20	
	30	50	-10	0	13	10	8	8	8	8	13	16	24	-120	20	
P6 (ABEC-3)	0.3	2.5	-12		15	12	9	9	9	9	15	15	20	-120	25	
	2.5	10	-15		19	19	11	11	11	11	20	20	25	-150	25	
	18	30	-7		9	7	5	5	5	5	5	8	10	-40	12	
	30	50	-7		9	7	5	5	5	5	5	8	10	-120	15	
P5 (ABEC-5)	0.6	2.5	-4		5	4	3	3	3	3	5	5	7	-40	20	
	2.5	10	-4		5	4	3	3	3	3	4	4	7	-120	20	
	18	30	-4		5	4	3	3	3	3	4	4	7	-120	20	
	30	50	-6		6	4	3	3	3	3	4	4	7	-120	20	
P4 (ABEC-7)	0.6	2.5	-4		9	4	3	3	3	3	4	4	7	-150	25	
	2.5	10	-4		9	4	3	3	3	3	4	4	7	-40	5	
	18	30	-4		9	4	3	3	3	3	4	4	7	-40	5	
	30	50	-4		9	4	3	3	3	3	4	4	7	-120	5	

注: Notes:
1. 表6.2的数值摘自GB/T 307.1-2005滚动轴承向心轴承公差, JB/T 53415-94(JB/CQ124-90)
微型球轴承及其零件补充技术要求, JB/T 10336-2002滚动轴承及其零件补充技术要求。
Table 6.2 are abstracted from GB/T 307.1-2005 Rolling bearing Radial bearing tolerance, tolerance, Miniture ball bearing and accessory complementary technical condition in JB/T 53415-94 (JB/CQ124-90)
1) P0, P6级的Sia值GB/T 307.1-2005未规定, JB/T 53415-94和JB/T 10336-2002中有规定。

Sea values for P0, P6 Classes are not dictated in GB/T 307.1-2005, but they have been dictated in J B/T 53415-94 and J B/T 10336-2002
2) 括弧内为原国家标准直径系列代号(新标准中7、8系列无规定)。
Brackets are diameter series symbols in original national standard(7,8 series are not dictated in new standard)

表6.3 P0 P6 P5 P4级尺寸公差级旋转精度-外圈
Table6.3 P0 P6 P5 P4 Classes tolerances-outer ring

公差等级 tolerances Class	D 外径 Outer diameter mm		Δ _{Dmp} 单一外径 平均偏差 Deviation of mean outside diameter		Δ _{DS} 单一外径 偏差 Deviation a single outside diameter		V _{dp} 单一外径变动量 Variation of single outside diameter				V _{dmp} 平均外径 变动量 Variation of mean outside diameter	Kea 外圈 径向 跳动 Run out of outer ring	Sd 外圈母线 与端面 垂直度 Variation of outside generation withing face	Sea* 端面与 滚动 跳动的 Axial runout of outer ring	Δ _{CS} 外圈单一 宽度偏差 Deviation of outer ring width		V _{CS} 外圈宽度 变动量 Variation of outer ring width
	超过 Over	到 incl	上偏差 max	下偏差 max	上偏差 max	下偏差 max	开型 Open	闭型 Close	最大 max	最大 max							
					最大 max		9** (7.8.9)	0.1** (1.7)	2.3.4 (2.3.4)	P0 (2.3.4) 0.1.2.3.4							
P0*** (ABEC-1)	2.5	6	-8		10	8	6	6	6	6	6	15	10	24	-40	12	
	6	18	-8		10	8	6	6	6	6	6	15	10	24	-120	15	
	18	30	-9	0	12	9	7	7	7	7	7	15	14	30	-120	20	
	30	50	-11		14	11	8	8	8	8	8	20	16	36/40	-120	20	
P6 (ABEC-3)	0.3	6	-13		16	13	10	10	10	10	10	25	16	40	-120	25	
	6	18	-15		19	19	11	11	11	11	11	35	20	40	-150	25	
	18	30	-7		9	7	5	5	5	5	5	8	8	12	-40	5	
	30	50	-7		9	7	5	5	5	5	5	8	8	12	-120	5	
P5 (ABEC-5)	0.6	6	-4		5	4	3	3	3	3	3	5	5	8	-40	20	
	6	18	-4		5	4	3	3	3	3	3	5	5	8	-120	20	
	18	30	-4		5	4	3	3	3	3	3	5	5	8	-120	20	
	30	50	-4		5	4	3	3	3	3	3	5	5	8	-120	20	
P4 (ABEC-7)	0.6	6	-4		9	4	3	3	3	3	3	5	5	8	-150	25	
	6	18	-4		9	4	3	3	3	3	3	5	5	8	-40	5	
	18	30	-4		9	4	3	3	3	3	3	5	5	8	-40	5	
	30	50	-4		9	4	3	3	3	3	3	5	5	8	-120	5	

注: Notes:
1. 表6.3的数值摘自GB/T 307.1-2005滚动轴承向心轴承公差, JB/T 53415-94(JB/CQ124-90)
微型球轴承及其零件补充技术要求, JB/T 10336-2002滚动轴承及其零件补充技术要求。
Table 6.3 are abstracted from GB/T 307.1-2005 Rolling bearing Radial bearing tolerance, tolerance, Miniture ball bearing and accessory complementary technical condition in JB/T 53415-94 (JB/CQ124-90)
1) P0, P6级的Sea值GB/T 307.1-2005未规定, JB/T 53415-94和JB/T 10336-2002中有规定。

Sea values for P0, P6 Classes are not dictated in G B/T 307.1-2005, but they have been dictated in J B/T 5341 5-94 and J B/T 10336-2002
2) 括弧内为原国家标准直径系列代号(新标准中7、8系列无规定)。
Brackets are diameter series symbols in original national standard(7,8 series are not dictated in new standard)

与同一轴承内圈的
Δ_{BS}及V_{BS}相同

Δ_{BSa} V_{BS} same with
bearing's inner ring

7. 轴承振动

轴承的振动级别用Z、Z₁、Z₂、Z₃、Z₄来表示，采用S0910仪器来检测。当有特殊要求时可用BVT-1来检测，用V₁、V₂、V₃、V₄表示。客户订货应注明振动要求。

7. BEARING VIBRATION

Vibration of bearings is represented by Z、Z₁、Z₂、Z₃、and Z₄ it is tested by S0910 instrument on acceleration basis. For special requirement of speed vibration control, the bearings are tested by BVT-1 instrument and divided into V₁、V₂、V₃、and V₄

轴承内径 Bearing bored(m m)	振动 (加速度) Vibration(Acceleration) 单位: db														
	直径系列 (0)Diameter Series(0)					直径系列 (2)Diameter Series(2)					直径系列 (3)Diameter Series(3)				
	Z	Z1	Z2	Z3	Z4	Z	Z1	Z2	Z3	Z4	Z	Z1	Z2	Z3	Z4
5	37	36	34	30	-	38	37	34	32	-	39	37	35	33	-
6	37	36	34	30	-	38	37	34	32	-	39	37	35	33	-
7	39	38	35	31	-	40	38	36	34	-	-	-	-	-	-
8	39	38	35	31	-	40	38	36	34	-	-	-	-	-	-
9	41	40	36	32	-	42	40	37	35	-	-	-	-	-	-
10	43	42	38	33	-	44	42	39	35	30	46	44	40	37	32
12	44	43	39	34	-	45	43	39	35	30	47	45	40	37	32
15	45	44	40	35	-	46	44	41	36	31	48	46	42	38	33
17	46	44	40	35	-	47	45	41	36	31	49	47	42	38	33
20	47	45	41	36	-	48	46	42	38	33	50	48	43	39	34
25	48	46	42	38	-	49	47	43	40	36	51	49	44	41	37
28	49	47	43	39	-	50	48	44	41	37	52	50	45	42	38
30	49	47	43	39	-	50	48	44	41	37	52	50	45	42	38
32	50	48	44	40	-	51	49	45	42	38	53	51	46	43	39
35	51	49	45	41	-	52	50	46	43	39	54	52	47	44	40
40	53	51	46	42	-	54	52	47	44	40	56	54	49	45	41
45	55	53	48	45	-	56	54	49	46	43	58	56	51	47	44
50	57	54	50	47	-	58	55	51	48	45	60	57	53	49	46

轴承内径 Bearing bored (mm)	振动 (速度) Vibration(Speed) 单位: db											
	V ₁			V ₂			V ₃			V ₄		
	低频 Low frequency	中频 Medium frequency	高频 High frequency	低频 Low frequency	中频 Medium frequency	高频 High frequency	低频 Low frequency	中频 Medium frequency	高频 High frequency	低频 Low frequency	中频 Medium frequency	高频 High frequency
5	74	48	40	58	36	30	35	21	18	32	11	11
6	74	48	40	58	36	30	35	21	18	32	11	11
7	92	66	54	72	48	40	44	28	24	38	12	12
8	92	66	54	72	48	40	44	28	24	38	12	12
9	92	66	54	72	48	40	44	28	24	38	12	12
10	120	80	70	90	60	50	55	35	30	45	14	14
12	120	80	70	90	60	50	55	35	30	45	14	14
15	150	110	85	110	78	60	65	46	35	52	18	18
17	150	110	85	110	78	60	65	46	35	52	25	25
20	180	125	100	130	100	75	80	60	45	60	30	32
25	180	125	100	130	100	75	80	60	45	60	30	32
28	180	125	100	130	100	75	80	60	45	60	35	40
30	200	150	130	150	120	100	90	75	60	70	35	40
32	200	150	130	150	120	100	90	75	60	70	35	40
35	200	150	130	150	120	100	90	75	60	70	42	45
40	240	180	160	180	150	130	110	90	80	82	50	50
45	240	180	160	180	150	130	110	90	80	82	60	60
50	280	200	200	210	160	160	125	100	100	95	70	70

8. 轴承的内部游隙

轴承的内部游隙是指将内圈或外圈中的一个固定，另一个移动时的最大移动量。径向移动量称为径向内部游隙，轴向移动量称为轴向内部游隙 (图8.1)。

运转时内部游隙 (工作游隙) 的大小对轴承的疲劳寿命、温升、噪声、振动等性能有影响。

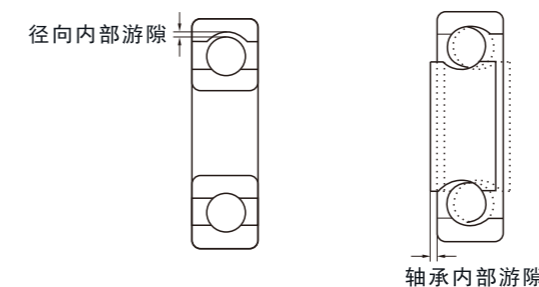


图8.1 轴承的内部游隙

测量轴承的内部游隙时，为得到稳定的测量值，一般对轴承施加规定的测量负荷。因此，所得到的测量值比真正的游隙 (理论游隙) 大，即增加了测量负荷产生的弹性变形量。

安装前轴承的内部游隙一般称为理论游隙。

8.1 内部游隙的选择

从理论游隙减去轴承安装到轴或座时因过盈配合产生的套圈膨胀量或收缩量后的游隙称做“安装游隙”。

在安装游隙上加减因轴承内部温差产生的尺寸变动后的游隙称为“有效游隙”。

轴承安装在机械上承受一定的负荷旋转时的内部游隙，即有效游隙加上轴承负荷产生的弹性变形量后的游隙称为“工作游隙”。

如图8.2所示，当工作游隙为微小正值时，轴承的疲劳寿命最长，但随着负游隙的增大疲劳寿命则显著下降，因此，选择轴承的内部游隙时，一般使工作游隙为零或略为正为宜。

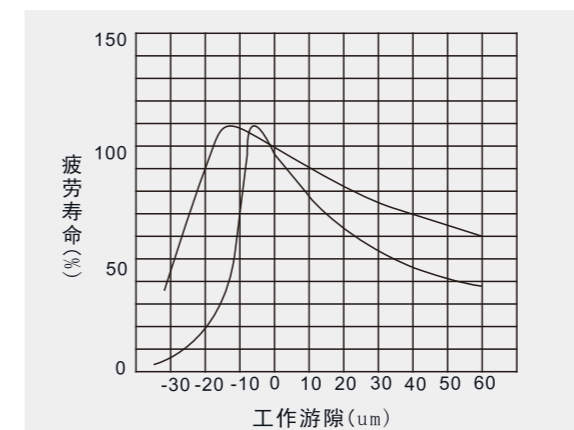


图8.2 工作游隙与疲劳寿命的关系

8. BEARING INTERNAL CLEARANCES

The bearing internal clearance is the max moving amount from moving another ring when one ring (innerring or outer ring) is fixed. The internal clearance is the total amount that one ring can be displaced relative to the other in the radial and axial directions respectively (Fig8.1).

The internal clearance in operation greatly influences bearing performance including fatigue life, heat-generation, noise, and vibration etc.

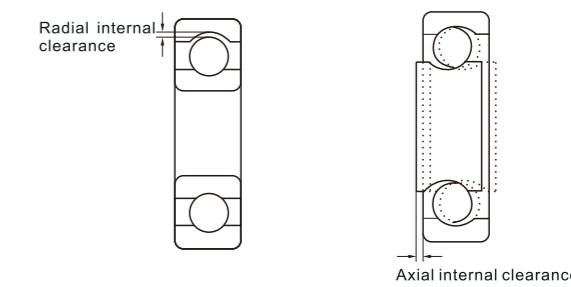


Fig8.1 Bearing Internal Clearances

To obtain accurate measurements, the clearance is generally measured by applying a specified measuring load on the bearing. Therefore, the measured clearance is always slightly larger than the actual clearance (sometimes called theoretical clearance), that is to say, the amount of elastic deformation is added in the process of measuring.

The clearance before mounting is usually called as the theoretical internal clearance .

8.1 Selection of Bearing Internal Clearances

The internal clearance after subtracting the decrement from the theoretical internal clearance is called "mounting clearance".

The mounting clearance after subtracting the radial clearance due to temperature difference between inner rings with outer rings is called "effective clearance".

The internal clearance after mounting bearing in a machine . means the effective clearance plus the clearance which is occurred after elastic deformation by bearing load, is called "operating clearance" .

As Fig 8.2 showing, the longest fatigue life of a bearing can be expected when the operating clearance is slightly positive, but an excessive negative operating clearance will greatly shorten the bearing life. Therefore, when selecting the internal clearance, ensuring the operating clearance equals zero or a slightly positive amount would be proper.

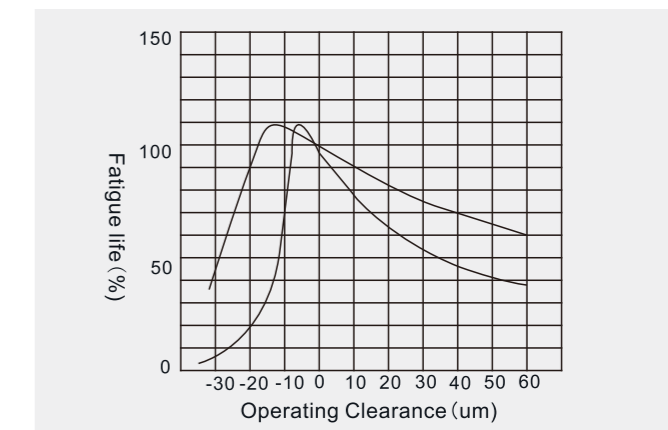


Fig 8.2 The Relationship between Operating Clearance and Fatigue Life

另外，为提高轴承刚性或降低噪声时，工作游隙要进一步取负值，而在轴承温升剧烈时，工作游隙则要进一步取正值等，还必须根据使用条件做具体分析。

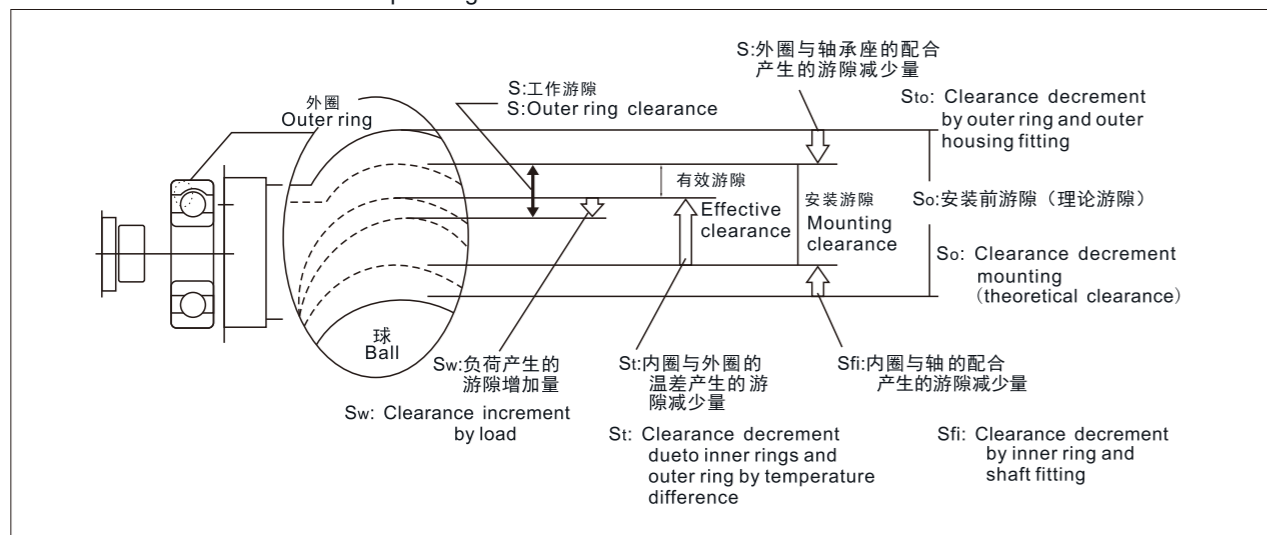
8.2 工作游隙

表8.1所示为计算钢制轴与钢制轴承座时的工作游隙的量。

非(CN)间隙选择的一些实例列于表8.2。

表8.1 工作游隙的计算方法

Table 8.1 Calculation Methods for Operating Clearance



In addition, in order to improve rigidity or reduce vibration, the operating clearance should be selected much more negative. The operating clearance should be selected much more positive when the temperature of bearing is raised strongly. It depends on actual applications.

8.2 Operating Clearances

Table 8.1 is applicable to calculate the amount of operating clearance for steel shaft and steel housing.

Some examples of non CN clearance selection are listed in table 8.2.

表8.2/ Table 8.2

工作游隙 (S) Operating clearance	$S = S_0 - (S_f + S_{t1} + S_{t2}) + S_w$	负荷产生的游隙增加量Sw也可以计算，但由于量小，一般不考虑	The clearance increment by load is equal to 0, it is not generally considered
配合产生的游隙减少量 Clearance decrement by fitting	中空轴 Hollow Shaft $S_f = \Delta d_{eff} \frac{d}{D_i} \frac{1}{1 - \frac{d_o^2}{D_i^2}}$ 实心轴 Solid Shaft $S_f = \Delta d \frac{d}{D_i}$	$D_h \neq \infty$ $S_{fo} = \Delta d_{eff} \frac{D_o}{D} \frac{1}{1 - \frac{D_o^2}{D_h^2}}$	$D_h = \infty$ $S_{fo} = \Delta d_{eff} \frac{D_o}{D}$
内圈与外圈的温差产生的游隙减少量 Clearance decrement by temperature difference between inner ring and outer ring	与轴承座状况有关，但一般可设外径膨胀量为0而近似地用下式计算： $S_{t1} = \alpha(D_i - T_i - D_o - T_o)$ Related with housing type, generally supposing outside diameter expansion is zero and calculating it approximately using following equation: $S_{t1} = \alpha(D_i - T_i - D_o - T_o)$	这里， $De = D_i + 2D_w$ 。因此 $S_{t1} + S_{t2}$ 可由下式计算。 $S_{t1} + S_{t2} = \alpha \cdot D_i \cdot T_1 + 2\alpha \cdot D_w \cdot T_2$ T_1 为内圈与外圈的温差 $T_1 = T_i - T_o$	Where, $De = D_i + 2D_w$ Therefore, $S_{t1} + S_{t2}$ can calculate by following equation $S_{t1} + S_{t2} = \alpha \cdot D_i \cdot T_1 + 2\alpha \cdot D_w \cdot T_2$ T_1 is the temperature difference between inner ring with outer ring $T_1 = T_i - T_o$
滚动体的温升产生的游隙减少量 Clearance decrement by the rolling element temperature rising	$S_{t2} = 2\alpha \cdot D_r \cdot T_r$	T_2 为滚动体与外圈的温差 $T_2 = T_r - T_o$	T_2 is the temperature difference between rolling elements with outer ring $T_2 = T_r - T_o$

在表8.3中，

- S — 工作游隙, mm;
- S_0 — 理论游隙, mm;
- S_f — 配合产生的游隙减少量, mm;
- S_{fi} — 内圈滚道直径的膨胀量, mm;
- S_{fo} — 外圈滚道直径的收缩量, mm;
- S_{t1} — 内圈与外圈的温差产生的游隙减少量, mm;
- S_{t2} — 滚动体的温升产生的游隙减少量, mm;
- S_w — 负荷产生的游隙增加量, mm;
- Δd_{eff} — 内圈的有效过盈, mm;
- d — 轴承公称内径, mm;
- d_o — 中空轴内径, mm;
- D_i — 内圈滚道直径, mm;

球轴承..... $D_i \approx 0.2(D+4d)$;
滚子轴承..... $D_i \approx 0.25(D+3d)$;

- ΔD_{eff} — 外圈的有效过盈, mm;
- D_h — 外壳外径, mm;
- D_o — 外圈滚道直径, mm;

球轴承..... $D_o \approx 0.2(4D+d)$;
滚子轴承..... $D_o \approx 0.25(3D+d)$;

- D — 轴承公称外径, mm;
- α — 轴承钢的线膨胀系数, $(12.5 \times 10^{-6}) 1/^\circ\text{C}$;
- D_w — 滚动体平均直径, mm;
- 球轴承..... $D_r \approx 0.2(D-d)$;
- 滚子轴承..... $D_r \approx 0.25(D-d)$;
- T_i — 内圈的温升, $^\circ\text{C}$;
- T_o — 外圈的温升, $^\circ\text{C}$;
- T_r — 滚动体的温升, $^\circ\text{C}$ 。

In the table 8.3

- S — Operating clearance, mm;
- S_0 — Theoretical clearance, mm;
- S_f — Clearance decrement by fitting, mm;
- S_{fi} — The expansion in raceway diameter of inner ring, mm;
- S_{fo} — The shrinkage in raceway diameter of outer ring, mm;
- S_{t1} — Clearance decrement by temperature difference between inner ring and outer ring, mm;
- S_{t2} — Clearance decrement by the rolling element temperature rising, mm;
- S_w — Clearance increment by load, mm;
- Δd_{eff} — Effective interference of inner ring, mm;
- d — Nominal bearing bore diameter, mm;
- d_o — Hollow shaft bore diameter, mm;
- D_i — Raceway diameter of inner ring, mm;
- Ball bearing..... $D_i \approx 0.2(D+4d)$;
- roller bearing..... $D_i \approx 0.25(D+3d)$;

- ΔD_{eff} — Effective interference of outer ring, mm;
- D_h — Housing outside diameter, mm;
- D_o — Raceway diameter of outer ring, mm;
- Ball bearing..... $D_o \approx 0.2(4D+d)$;
- roller bearing..... $D_o \approx 0.25(3D+d)$;

- D — Nominal bearing outside diameter;
- α — The coefficient of linear expansion in bearing steel (12.5×10^{-6}) $1/^\circ\text{C}$;

- D_r — Average of rolling element diameter, mm;
- Ball bearing..... $D_r \approx 0.2(D-d)$;
- roller bearing..... $D_r \approx 0.25(D-d)$;

- T_i — Inner ring temperature rise, $^\circ\text{C}$;
- T_o — Outer ring temperature rise, $^\circ\text{C}$;
- T_r — Roller temperature rise, $^\circ\text{C}$ 。

表8.3 标准(CN)游隙以外的游隙选择示例

使用条件	用例	游隙选择示例
重负荷或冲击负荷且过盈大	铁路车辆车轴	C3
振动或冲击负荷且内圈与外圈均为过盈配合	振动筛 铁路车辆 主电动机 拖拉机 末级减速装置	C3、C4 C4 C4
轴的挠曲大	汽车后轮	C5
轴与内圈受到加热	造纸烘干机 轧钢机辊子	C3、C4 C4
内圈与外圈均为间隙配合	轧钢机辊道颈	C2
需降低旋转时的噪声与振动	微型马达	C2、C2、CM
为减小轴的跳动，对安装游隙	车床主轴	C9NA、C1NA

Table 8.3 Selecting clearances for Specific Applications

Operating condition	Examples	Internal clearance
Big interference heavy load or shock load	Railway vehicle axl	C3
Vibration load or shock load, all tight fits for outer ring and inner ring	Vibrating screen Traction motor Final reduction gear for tractor	C3、C4 C4 C4
Large shaft deflection	Automotive rear wheel	C5
High temperature on shaft and inner ring	Paper dryer Axle neck for rolling mill	C3、C4 C4
All loose fit for inner rings and out rings	Axle neck for rolling mill	C2
Special rotating noise and vibration	micro motor	C2、C2、CM
Special run out requirement	Lathe spindle	C9NA、C1NA

对于轴或轴承座为非钢材料，或采用分析汽车轴承的内部游隙时常用统计方法，或分析使用条件特殊时的内部游隙时，请与MOGB联系。

9. 轴承游隙

9.1 轴承游隙和规格

游隙是轴承内圈、外圈、滚动体之间的间隙量。轴承有径向游隙及轴向游隙。

表9.1 深沟球轴承的径向游隙

公称轴承内径 d(mm)	游隙												
	C2		CN		C3		C4		C5				
超过	到	最小	最大	最小	最大	最小	最大	最小	最大	最小	最大	最小	最大
-	2.5	0	6	4	11	10	20	-	-	-	-	-	-
2.5	6	0	7	2	13	6	23	-	-	-	-	-	-
6	10	0	7	2	13	8	23	14	29	20	37		
10(限于)	10	0	7	2	13	8	23	14	29	20	37		
10	18	0	9	3	18	11	25	18	33	25	45		
18	24	0	10	5	20	13	28	20	36	28	48		
24	30	1	11	5	20	13	28	23	41	30	53		
30	40	1	11	6	20	15	33	28	46	40	64		
40	50	1	11	6	23	18	36	30	51	45	73		
50	65	1	15	8	28	23	43	38	61	55	90		
65	80	1	15	10	30	25	51	46	71	65	105		
80	100	1	18	12	36	30	58	53	84	75	120		

9.2 小型球轴承(D≥9, d<10)、微型球轴承(D<9)的径向游隙

表9.2 单位：微米

游隙代号	MC1		MC2		MC1		MC2		MC1		MC2	
	最小	最大	最小	最大	最小	最大	最小	最大	最小	最大	最小	最大
游隙	0	5	3	8	5	10	8	13	13	20	20	28

备注：标准游隙为MC3

9.3 电机轴承径向游隙

表9.3 单位：微米

内径 d (mm)		游隙 d (mm)	
超过	到	最小	最大
10(包括)	18	4	11
18	30	5	12
30	50	9	17

When shafts or housings are not made of steel, or adopting the statistic method usually used in analyzing automotive bearing internal clearance, or analyzing internal clearance under special condition, please contact with MOGB.

9. BEARING CLEARANCE

9.1 Bearing Clearance and Specification

Clearance is the gap among bearing inner ring, outerring and rolling elements. Bearing has radial clearance and axial clearance.

Table 9.1 deep-groove ball bearing radial clearance

Nominal bearing bore diameter d(mm)	Clearance												
	C2		CN		C3		C4		C5				
over	incl.	Min.	Max.	Min.	Max.	Min.	Max.	Min.	Max.	Min.	Max.	Min.	Max.
-	2.5	0	6	4	11	10	20	-	-	-	-	-	-
2.5	6	0	7	2	13	6	23	-	-	-	-	-	-
6	10	0	7	2	13	8	23	14	29	20	37		
10	10	0	7	2	13	8	23	14	29	20	37		
10	18	0	9	3	18	11	25	18	33	25	45		
18	24	0	10	5	20	13	28	20	36	28	48		
24	30	1	11	5	20	13	28	23	41	30	53		
30	40	1	11	6	20	15	33	28	46	40	64		
40	50	1	11	6	23	18	36	30	51	45	73		
50	65	1	15	8	28	23	43	38	61	55	90		
65	80	1	15	10	30	25	51	46	71	65	105		
80	100	1	18	12	36	30	58	53	84	75	120		

9.2 Radial Internal Clearance of Small (D≥9, d<10) and Miniature (D<9) Bearings

Table 9.2 Unit: μm

游隙代号	MC1		MC2		MC1		MC2		MC1		MC2	
	Min.	Max.	Min.	Max.	Min.	Max.	Min.	Max.	Min.	Max.	Min.	Max.
Clearance	0	5	3	8	5	10	8	13	13	20	20	28

Note: Normal Clearance is MC3

9.3 Radial Clearance of Motor Bearing

Table 9.3 Unit: μm

Bore d (mm)		Clearance d (mm)	
over	incl.	Min.	Max.
10(incl)	18	4	11
18	30	5	12
30	50	9	17

10. 轴承的配合

10.1 配合的目的

配合的目的是使轴承内圈或外圈牢固地与轴或轴承座固定，以免在相互配合面上出现不利的周向滑移。

这种不利的周向滑移（称做蠕变）会引起异常发热配合面磨损（进而使磨损铁粉侵入轴承内部）以及振动等各种问题，使轴承不能发挥作用。

因此对于轴承来说，由于承受负荷旋转，一般必须让套圈过盈配合使之可靠地与轴或外壳固定。

10.2 轴及轴承座的尺寸公差与配合

公制系列的轴及轴承座的尺寸公差以ISO286为基准，从中选定尺寸公差即可确定轴承与轴或轴承座的配合。

轴及轴承座的尺寸公差与P0级精度的轴承的配合关系如图10.1所示。

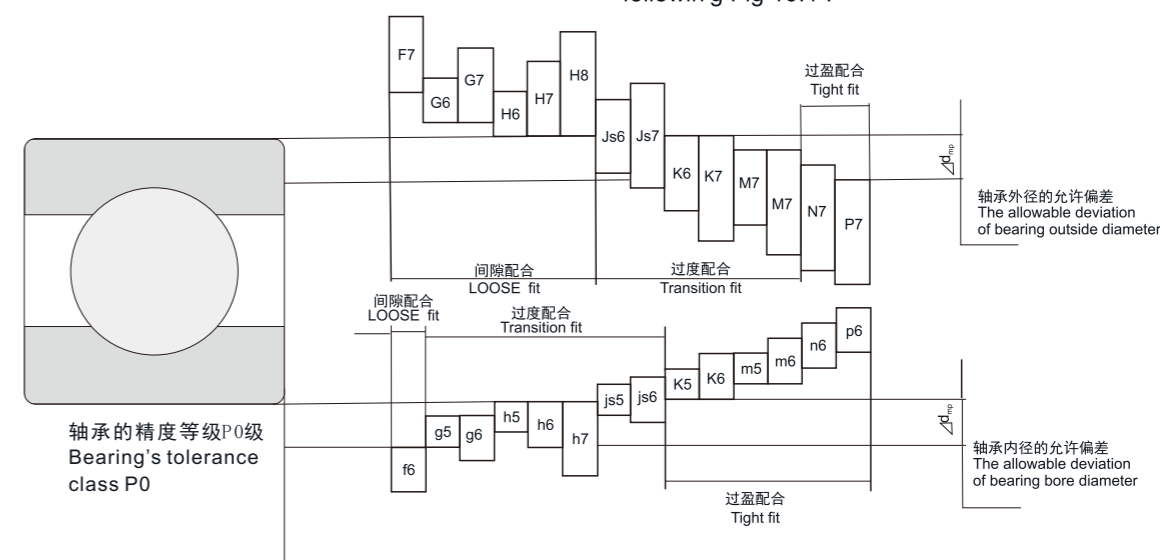


图10.1/Fig 10.1

10.3 配合的选择

选择配合时，应充分考虑轴承的使用条件。考虑的项目大致如下：

- 负荷的性质与大小
- 运转时的温度分布
- 轴承内部游隙
- 轴与轴承序的加工质量、材质及壁厚结构
- 安装与拆卸方法
- 是否需要利用配合面吸收轴的热膨胀
- 轴承的型式与尺寸

下面，结合上述各项目，说明一下配合的选择。

1) 负荷性质的影响

轴承负荷可分为内圈旋转负荷，外圈旋转负荷及不定向负荷，其与配合的关系如表10.2所示。

10. BEARING FITS

10.1 The Purpose of Fits

The purpose of fits is that let bearing inner ring or outer ring be both fixed firmly with shaft or housing, in case any circumferential slipping is occurred on the matching surface.

This kind of slipping which is called "creep" will cause many faults, such as: abnormal heating, the matching surface wear (abrasive metallic particles ingress the interior of the bearing) and vibration etc. It may destroy the bearing function.

Therefore, it is important to let rings have tight fit in order that they are firmly fixed with shaft or housing.

10.2 The Dimension Tolerance and Fit of Shaft or Housing

The metric dimension tolerance of shaft and housing bore is based on ISO 286, selecting the dimension tolerance from this standard to decide the fit situation between shaft, housing and bearing.

Regarding the dimension tolerance of shaft or housing bore & the fit relationship of bearing tolerance class P0, see the following Fig 10.1.

10.3 Selection of Fits

It should fully be considered the bearing application condition when selects fits. It should be considered the following items generally:

- Types and magnitude of load
- The distributing of operational temperature
- The internal clearance of bearing
- The processing quality of shaft and housing, material and housing thickness as well as structure
- Means of bearing mounting and dismounting
- Whether or not use matching surface to avoid the heat expansion of shaft
- The type and dimension of bearing

The following are connection with above items to explain selection of fits.

1) The Influence of Load Conditions

Basic on conditions, the bearing load can be divided into inner ring rotating load, outer ring rotating load and indeterminate direction load. The details can be found in Tab 10.2.

表10.2 负荷的性质与配合的关系

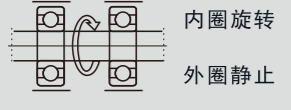

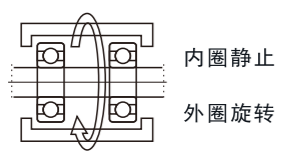
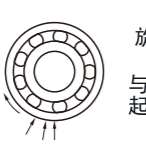
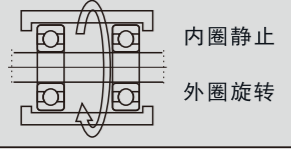
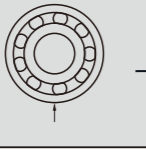
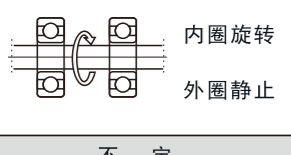

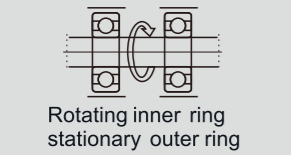
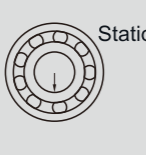
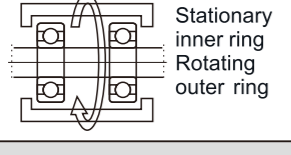
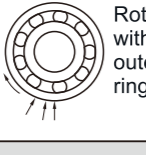
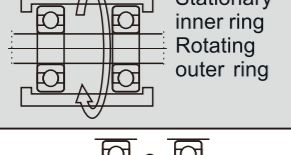
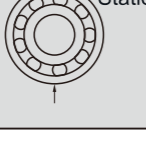
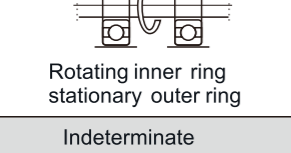
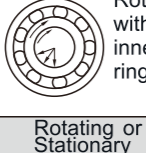
旋转零件	负荷方向	负荷性质	配合		用 例
			内圈与轴	外圈与轴承座	
 内圈旋转 外圈静止	 一定	内圈旋转 负荷	过盈配合 (k, m, n, p, r)	间隙配合 (F, G, H, JS)	正齿轮装置 电动机
 内圈静止 外圈旋转	 旋转 与外圈 起旋转	外圈静止 负荷			平衡差的 车轮
 内圈静止 外圈旋转	 一定	内圈静止 负荷	间隙配合 (f, g, h, js)	过盈配合 (K, M, N, P)	带固定轴 的行走轮 和滑轮
 内圈旋转 外圈静止	 旋转 与外圈 起旋转	外圈旋转 负荷			振动筛 不平衡 振动
不 定	旋转或一定	不定向负荷	过盈配合	过盈配合	曲 轴

Table 10.2 The Relationship between Load Conditions and Fit

Bearing operation	Load direction	Load condition	Fits		Example
			Inner ring and shaft	Outer ring and housing	
 Rotating inner ring stationary outer ring	 Stationary	Rotating inner ring load	Tight fit (k, m, n, p, r)	Loose fit (F, G, H, JS)	Electromotor with spur gear box
 Stationary inner ring Rotating outer ring	 Rotating with outer ring	Stationary outer ring load			Imbalance wheel
 Stationary inner ring Rotating outer ring	 Stationary	Rotating inner ring load	Loose fit (f, g, h, js)	Tight fit (K, M, N, P)	Running wheel and pulley with fix shaft
 Rotating inner ring stationary outer ring	 Rotating with inner ring	Stationary outer ring load			Vibrating screens (imbalance vibration)
Indeterminate	Rotating or Stationary	Indeterminate direction load	Tight fit	Tight fit	Crankshaft

2) 负荷大小的影响

内圈在径向负荷作用下，半径方向即被压缩又有所伸展，周长趋于微小增加，因此初始过盈将减少。过盈减少量可由下列计算

$$F_r \leq 0.25C_0 \text{ 时} \\ \Delta d_f = 0.08 \sqrt{\frac{d}{B}} \cdot F_r \times 10^3 \quad \dots\dots 10.1$$

$$F_r > 0.25C_0 \text{ 时} \\ \Delta d_f = 0.02 \frac{F_r}{B} \times 10^3 \quad \dots\dots 10.2$$

这里，

- Δd_f — 内圈的过盈减少量，mm；
- d — 轴承公称内径，mm；
- B — 内圈公称宽度，mm；
- F_r — 径向负荷，N；
- C_0 — 基本额定静负荷，N。

因此，当径向负荷为重负荷（超过 C_0 值的25%）时，配合必须比轻负荷时紧。

若是冲击负荷，配合必须更紧。

3) 配合面粗糙度的影响

若考虑配合面的塑性变形，则配合后的有效过盈受配合而加工质量的影响，近似地可用下列表示。

磨削轴

$$\Delta D_{eff} \approx \frac{d}{d+2} \Delta d \quad \dots\dots 10.3$$

车削轴

$$\Delta D_{eff} \approx \frac{d}{d+3} \Delta d \quad \dots\dots 10.4$$

这里，

- Δd_{eff} — 有效过盈，mm；
- Δd — 目标过盈，mm；
- d — 轴承公称内径，mm；

4) 温度的影响

一般来说，运转时的轴承温度高于周边温度，而且轴承带负荷旋转时，内圈温度高于轴温，因此热膨胀将使有效过盈减少。

现设轴承内部与轴承座周边的温度为 ΔT ，则可假定内圈与轴在配合面的温差近似为 $(0.10 \sim 0.15) \Delta T$ 。因此温差产生的过盈减少量 Δd_t ，可由下式计算：

$$\Delta d_t = (0.10 \sim 0.15) \Delta T \cdot \alpha \cdot d \\ \approx 0.0015 \Delta T \cdot d \times 10^{-3} \quad \dots\dots 10.5$$

其中，

- Δd_t — 温差产生的过盈减少量，m；
- ΔT — 轴承内部与轴承座周边的温差， $^{\circ}\text{C}$ ；
- α — 轴承钢的线膨胀系数， $(12.5 \times 10^{-6}) / ^{\circ}\text{C}$
- d — 轴承公称内径，mm。

2) The influence of load magnitude

When inner ring is under the radial load, inner ring is slightly increased in the load direction. Therefore initial magnitude of interference will be decreased. The loss of interference should be estimated using the following equations:

$$F_r \leq 0.25C_0 \\ \Delta d_f = 0.08 \sqrt{\frac{d}{B}} \cdot F_r \times 10^3 \quad \dots\dots 10.1$$

$$F_r > 0.25C_0 \\ \Delta d_f = 0.02 \frac{F_r}{B} \times 10^3 \quad \dots\dots 10.2$$

Where,

- Δd_f — Interference decrement of inner ring, mm;
- d — Nominal bearing bore diameter, mm;
- B — Nominal inner ring width, mm;
- F_r — Radial load applied on bearing, N;
- C_0 — Basic load rating, N.

Therefore, when the radial load is heavy load (the value exceeds 25% of C_0), the fit must become tighter than light load. If it impacts load, the fitting must tighter.

3) The influence of matching surface roughness

If the plastic deformation of matching surface is considered, the effective interference will be influenced by the roughness of matching surface. It may use the following equations:

For grinding shafts

$$\Delta D_{eff} \approx \frac{d}{d+2} \Delta d \quad \dots\dots 10.3$$

For machining shafts

$$\Delta D_{eff} \approx \frac{d}{d+3} \Delta d \quad \dots\dots 10.4$$

Where,

- Δd_{eff} — Effective interference, mm
- Δd — Ideal interference, mm
- d — Bore diameter, mm

4) The influence of temperature

Generally speaking, the bearing operating temperature is higher than surrounding, moreover, when bearing rotating with load, the temperature of inner ring is higher than shaft, so the effective interference decreases due to heat expansion. If the temperature difference between the bearing and housing is ΔT , then the temperature difference between the matching surfaces of the shaft and inner ring is estimated to be about $(0.10 \sim 0.15) \Delta T$. The decrement in the interference of the inner ring due to this temperature difference Δd_t may be calculated using Equation:

$$\Delta d_t = (0.10 \sim 0.15) \Delta T \cdot \alpha \cdot d \\ \approx 0.0015 \Delta T \cdot d \times 10^{-3} \quad \dots\dots 10.5$$

Where,

- Δd_t — Decrement in interference of inner ring due to temperature difference, mm;
- ΔT — Temperature difference between bearing interior and surrounding parts, $^{\circ}\text{C}$;
- α — Coefficient of linear expansion of bearing steel $(12.5 \times 10^{-6}) / ^{\circ}\text{C}$
- d — Nominal bearing bore diameter, mm.

因此，当轴承温度高于轴温时，配合必须变紧。

另外，在外圈与轴承座之间，由于温差或线膨胀系数的不同反过来有时过盈也会变化。因此在考虑利用外圈与轴承座配合面之间的滑动吸收轴的热膨胀时，需要加以注意。

5) 配合产生的轴承内部最大应力

轴承采用过盈配合安装时，套圈会膨胀或收缩，从而产生应力。应力过大时，有时套圈会破裂，需要加以注意。配合产生的轴承内部最大应力可由表10.3的公式计算，作为参考值，取最大过盈不超过轴径的1/1000，或由表10.3的计算式得到的最大应力 σ 不大于120MPa力安全。

6) 其他

旋转精度要求特别高时，应提高轴和轴承座的精度与轴相比，一般轴承座难加工，精度低，因此放松外圈与轴承座的配合为宜。采用中空轴及薄壁轴承座时，配合必须比通常紧。采用剖分型轴承座时，应放松与外圈的配合。对于铸铝或轻合金轴承座，配合必须比通常紧一些，这时请与MOGB联系。

表10.3 配合生产的轴承内部最大应力

轴与内圈	轴承座孔与外圈
$\sigma = \frac{E}{2} \cdot \frac{\Delta d_{eff}}{d} \cdot \frac{(1 - \frac{d_o^2}{d^2})(1 + \frac{d^2}{D_i^2})}{1 + \frac{d^2}{D_i^2}}$	$Dh \neq \infty \quad \sigma = E \cdot \frac{\Delta d_{eff}}{D} \cdot \frac{(1 - \frac{D_e^2}{D_h^2})}{(1 + \frac{D_e^2}{D_h^2})}$
$\sigma = \frac{E}{2} \cdot \frac{\Delta d_{eff}}{d} \cdot (1 + \frac{d^2}{D_i^2})$	$Dh = \infty \quad \sigma = E \cdot \frac{\Delta d_{eff}}{D}$

这里，

- σ —最大应力，MPa；
- d —轴承公称内径（轴径），mm；
- D_i —内圈滚道直径，mm；
 - 球轴承……… $D_i \approx 0.2(D+4d)$ ；
 - 滚轴承……… $D_i \approx 0.25(D+3d)$ ；
- Δd_{eff} —内目的有效过盈，mm；
- d_o —中空轴内径，mm；
- D_e —外圈滚道直径，mm；
 - 球轴承……… $D_e \approx 0.2(4D+d)$ ；
 - 滚球轴承……… $D_e \approx 0.25(3D+d)$ ；
- D —轴承公称外径（外壳孔径），mm；
- Δd_{eff} —外圈的有效过盈，mm；
- D_h —外壳外径，mm；
- E —弹性模量， $2.08 \times 10 \text{MPa}$ ；

备注：上式适用于钢制轴与轴承座。非钢性材料时，请与MOGB联系。

So, when the temperature of bearing is higher than shaft, the fit must tighter.

In addition, the interference may increase due to the temperature difference and the linear expansion coefficients all are different between outer ring and housing. Therefore, when considering avoiding heat expansion of shaft via sliding between outer ring and housing, we should pay more attention to this.

5) The maximum stress occurred by fitting in rings The rings will be expanded and shrunken due to tight fit mounting so that will cause internal stress. Excessive stress may lead ring broken, should pay more attention to this.

The maximum stress is occurred by fitting in bearing rings may be calculated by the equations in Table.10.3. For reference, it will be safe, when the maximum interference less than 1/1000 Of shaft diameter, or the maximum stress less than 120MPa where getting from the equations in section10.3.

6) Others

We should improve the precision of shaft and housing due to higher accuracy requirement. Comparing with shaft, the housing normally is difficult to machining and poor precision, so it should loose the fitting of outer ring and housing.A tighter fitting is necessary due to adopting the thin housing and hollow shaft. The fitting should be loosed due to adopting the split housing. The fitting should tighter than usual when adopting the aluminum or light alloy housing. It is advisable to consult MOGB.

Table10.3 The Maximum Stress Occurred by Fitting

Shaft&inner ring	Housing bore&outer ring
$\sigma = \frac{E}{2} \cdot \frac{\Delta d_{eff}}{d} \cdot \frac{(1 - \frac{d_o^2}{d^2})(1 + \frac{d^2}{D_i^2})}{1 + \frac{d^2}{D_i^2}}$	$Dh \neq \infty \quad \sigma = E \cdot \frac{\Delta d_{eff}}{D} \cdot \frac{(1 - \frac{D_e^2}{D_h^2})}{(1 + \frac{D_e^2}{D_h^2})}$
$\sigma = \frac{E}{2} \cdot \frac{\Delta d_{eff}}{d} \cdot (1 + \frac{d^2}{D_i^2})$	$Dh = \infty \quad \sigma = E \cdot \frac{\Delta d_{eff}}{D}$

Where,

- σ —Maximum stress, Mpa；
- d —Bearing nominal bore diameter (shaft diameter), mm；
- D_i —Raceway diameter of inner ring, mm；
 - Ball bearing……… $D_i \approx 0.2(D+4d)$ ；
 - Roller bearing……… $D_i \approx 0.25(D+3d)$ ；
- Δd_{eff} —Effective interference of inner ring, mm；
- d_o —Hollow shaft bore diameter, mm；
- D_e —Raceway diameter of outer ring, mm；
 - Ball bearing……… $D_e \approx 0.2(4D+d)$ ；
 - Roller bearing……… $D_e \approx 0.25(3D+d)$ ；
- D —Bearing nominal outside diameter(housing bore diameter), mm；
- Δd_{eff} —Effective interference of outer ring, mm；
- D_h —Outside housing diameter, mm；
- E —Elastic modulus $2.08 \times 10 \text{MPa}$.

[Remarks]: Above Equations are fitted for the steel shaft and housing, if the housing materials are not made of steel,please contact with MOGB.

10.4推荐配合

如10.1节所述，为选择合适的配合，必须考虑轴承负荷的性质及大小、温度、安装与拆卸方法等各种因素。但在实际确定配合时，还需要参考以往的经验。

公制系列轴承的常用配合如表10.4所示。各类轴承最常用的推荐配合如表10.5-表10.8所示。

表10.4公制系列轴承的常用配合

(1) 向心轴承内径的配合

轴承的精度等级 ¹⁾	内圈旋转负荷或方向变化负荷 轴的公差带							内圈静止负荷		
	r6	r6	n6	m6	k6	js6	h5	h6	g6	f6
O级、6级	r6	r6	n6	m6	k6	js6	h5	h6	g6	f6
5级	—	—	—	m5	k4	js4	h4	h5	—	—
配合	过盈配合				过渡配合			间隙配合		

(2) 向心轴承外径的配合

轴承的精度等级 ¹⁾	外圈静止负荷 孔的公差带						不定向负荷或外圈旋转负荷		
	G7	H7	JS7	—	JS6	K7	M7	N7	P7
O级、6级	G7	H7	JS7	—	JS6	K7	M7	N7	P7
5级	—	H5	JS5	K5	—	K5	M5	—	—
配合	间隙配合		过渡配合			过盈配合			

9.4 Recommended Fits

As section 10.1 described, many factors must be considered when selecting the proper fit, such as the characteristics and bearing load magnitudes, temperature differences, and methods of bearing mounting and dismounting. But in fact selecting the fitting, previous experience should be referred.

The fits for metric series bearings are used, as Tab 10.4 showing. The recommended fits for some common applications are shown in Tab 10.5-10.8.

Table 10.4 The General Fits of Metric Series Bearings

(1) Fits of Radial Bearing Bore

Precision class of bearing ¹⁾	Inner ring rotating load or indeterminate direction load							Inner ring stationary load		
	Tolerance range of shaft									
Class PO, P6	r6	r6	n6	m6	k6	js6	h5	h6	g6	f6
Class P5	—	—	—	m5	k4	js4	h4	h5	—	—
Fits	Tight fit				Transition fit			Loose fit		

(2) Fits of Radial Bearing Outside Diameter

Precision class of bearing ¹⁾	Outer ring stationary load				Indeterminate direction load or outer ring rotating load				
	Tolerance range of bore								
Class PO, P6	G7	H7	JS7	—	JS6	K7	M7	N7	P7
Class P5	—	H5	JS5	K5	—	K5	M5	—	—
Fits	Loose fit		Transition fit			Tight fit			

表10.5向心轴承（0级、6级）与轴的推荐配合

条件 ¹⁾	球轴承		轴的公差带	备注	用例（参考）
	超过	到			
内圈旋转负荷或方向变化的负荷	轻负荷或变化负荷 ($\frac{P_r}{C_r} \leq 0.06$)	—	18	h5	旋转精度要求高时，用js、k5、m5代替js6、k6、m6
		18	100	js6	
		100	200	K6	
		—	—	m6	
		—	18	js5	
	一般负荷 ($0.06 < \frac{P_r}{C_r} \leq 0.12$)	18	100	K5	对于单列角接触球轴承及圆柱滚子轴承及圆锥滚子轴承，因不需考虑配合引起的内部游隙的变化，因此可用k6、m6、代替k5、m5
		100	140	m5	
		140	200	m6	
		200	280	n6	
		—	—	p6	
重负荷或冲击负荷 ($\frac{P_r}{C_r} > 0.12$)	—	—	r6	需要使用内部游隙大于标准游隙的轴承	
	—	—	n6		
	—	—	p6		
内圈静止负荷	内圈必须易于在轴上移动		全轴径	g6	旋转精度要求高时，采用g5，对于大型轴承，为便于移动，也可采用f6
	内圈不需要易于在轴上移动		全轴径	h6	旋转精度要求高时，采用h5
仅中心轴向负荷			全轴径	js6	

轻负荷，一般负荷以及重负荷是指径向当量负荷(Pr)分别对应轴承的径向基本额定动负荷(Cr)的0~6%，6%~12%以及超过12%的负荷
注：本表适用于钢制实心轴。

Table 10.5 Fits of Radial Bearings (Class PO, Class P6) with Shafts

Load Conditions ¹⁾	Ball Bearings		Tolerance of shaft	Remarks	Examples
	Over	incl.			
Inner ring rotating load or indeterminate direction load	Light or variable Loads ($\frac{P_r}{C_r} \leq 0.06$)	—	18	h5	Using js5, k5, and m5 to instead of js6, k6, and m6 where higher accuracy is required.
		18	100	js6	
		100	200	K6	
		—	—	m6	
		—	18	js5	
	Normal Load ($0.06 < \frac{P_r}{C_r} \leq 0.12$)	18	100	K5	For single row angular contact ball bearing and single row tapered roller bearings, because the internal clearance is not considered, so using k6, m6 to instead of k5, m5.
		100	140	m5	
		140	200	m6	
		200	280	n6	
		—	—	p6	
Heavy load or Shock load ($\frac{P_r}{C_r} > 0.12$)	—	—	r6	It is necessary that internal clearance is bigger than CN clearance.	
	—	—	n6		
	—	—	p6		
Inner ring stationary load	Easy axial displacement of inner ring on shaft desirable		All size	g6	Use g5 where high accuracy is required. In order to easy move f6 could be used for large bearings.
	Easy axial displacement of inner ring on shaft unnecessary		All size	h6	Use h5 where higher accuracy is required.
Centric axial load only			Full shaft diameter	js6	

Note: Light loads indicate less than 6% of basic loads rating (C_r).Normalloads indicate more than 6% and less than 12% of basic loads rating (C_r). Heavy loads indicate more than 12% of basic loads rating (C_r). Remark: This table is applicable to solid steel shafts only.

表10.6向心轴承（0级、6级）与轴承座的推荐配合

条件			轴承座的公差带	备注	用例 (参考)	
外壳	负荷种类等 ¹⁾	外圈能否轴向移动 ²⁾				
整体型或部分型	外圈静止负荷	任意负荷	H7	对于大型轴承或外圈与轴承座的温差大时也可采用G7	一般轴承装置、铁路车辆轴承箱、传动装置等	
		轻负荷或一般负荷	H8	—	—	
		轴与内圈温度高	G7	对于大型轴承或外圈与轴承座的温差大时也可采用F7	干燥缸体等	
		要求在轻负荷或一般负荷下做高精度旋转	原则上不能移动	K6	主要适用于滚子轴承	—
	方向变化负荷	要求安静旋转	能移动	JS6	主要适用于滚子轴承	—
		轻负荷或一般负荷	易于移动	H6	—	—
		轻负荷或一般负荷	一般能移动	JS7	旋转精度要求高时，用JS6、K6代替JS7、K7	电动机、泵、曲轴轴承等
		一般负荷或重负荷	原则上不能移动	K7	—	—
		强烈冲击负荷	不能移动	M7	—	铁路车辆、主电动机等
		轻负荷或变化负荷	—	M7	—	传送带轮、索道滑车、张紧轮等
外圈旋转负荷	一般负荷或重负荷	不能移动	N7	主要适用于球轴承	装有球轴承的轮毂等	
	薄壁轴承座且为重负荷或强烈冲击负荷	—	P7	主要适用于滚子轴承	装有滚子轴承的轮、连杆的大端轴承等	

1) 负荷种类参照表10.2的注； 2) 表示非分离轴承的外圈能否轴向移动。
注：1. 本表适用于铸铁或钢制轴承座； 2. 轴承仅承受中心轴向负荷时，外圈与轴承座之间的配合应选择松配合的公差带。

Table 10.6 Fits of Radial Bearings (Class PO, Class P6) with Housings

Load Condition			Tolerance for housing bore	Remarks	Examples	
Housings	Load types ¹⁾	Axial displacement of outer ring				
Whole unit or split	Outer ring stationary load	Random load	H7	The high temperature difference between outer ring with housing or large bearing G7 can be used	General bearing applications, Railway vehicle axle, Axle box Transmission mechanism	
		Light or normal loads	H8	—	—	
		Higher temperature in the shaft and inner ring	G7	The high temperature difference between outer ring with housing or large bearing F7 can be used	Dry cylinder	
		Higher accuracy rotating is required under normal or light loads	Generally impossible	K6	Mainly appropriated for roller bearing	—
Whole unit	Indeterminate direction load	Low noise rotating	Possible	JS6	Mainly appropriated for ball bearing	—
		Light or normal loads	Easily possible	H6	—	—
		Normal or heavy load	Generally impossible	JS7	Where higher accuracy is required us7ng Js6 ,K6, to instead of JS7, K7	Electromotor, pumps, crankshaft
	Outer ring rotating load	Heavy shock load	Impossible	M7	—	Traction motor for railway vehicle
		Light or variable load	—	M7	—	Convey or rollers ropeway running pulleys, tension pulleys
		Heavy shock load	Impossible	N7	Mainly appropriated for ball bearing	Hub with ball bearing
Thin-wall housings and with heavy or heavy shock load	—	P7	Mainly appropriated for roller bearing	Hub with roller bearing		

Note : 1) Load types refer to Table 10.2. 2) Axial displacement of outer ring (non-separable bearing)
Remarks: 1. This table is applicable to cast iron and steel housings only. 2. When the bearings bear centric axial load only, fits between outer ring and housings should be the tolerance range of loose fits.

表10.7精密微型·小径球轴承(d<10mm)与轴的推荐配合

负荷条件	轴承的精度等级	轴承单一平面内平均内径的偏差 Δd_{mp}		轴径的偏差		配合 ¹⁾	用例
		上	下	上	下		
		内圈旋转负荷	中速/高速轻负荷及一般负荷	P5	0 -5.1 -5		
内圈旋转负荷	低速轻负荷	P4	0 -5.1 -4	+2.5	-2.5	7.6-2.5L 6.5-2.5L	陀螺仪空气净化装置 电动工具编码器
		P5	0 -5.1 -5	-2.5	-7.5	2.6-7.5L 2.5-7.5L	陀螺仪空气净化装置 伺服马达 软盘驱动器
外圈旋转负荷	低速/高速轻负荷	P4	0 -5.1 -4	-2.5	-7.5	2.6-7.5L 1.5-7.5L	压气机 带轮线性执行元件
		P5	0 -5.1 -5	-2.5	-7.5	2.6-7.5L 2.5-7.5L	—

注：1) 代号T与L分别表示过盈与间隙配合

表10.8精密微型·小径球轴承(D≤30mm)与外壳的推荐配合

负荷条件	轴承的精度等级	轴承单一平面内平均内径的偏差 Δd_{mp}		外壳孔径的偏差		配合 ¹⁾	用例
		上	下	上	下		
		内圈旋转负荷	中速/高速轻负荷及一般负荷	P5	0 -5.1		
P4	0 -5 -6			+5	0	0-10L 0-11L	
P4	0 -4 -5			+5	0	0-9L 0-10L	
低速轻负荷	P5		0 -5.1	+2.5	-2.5	2.5T-7.6L 2.5T-7.5L	陀螺仪空气净化装置 伺服马达 软盘驱动器
	P4		0 -5 -6	+2.5	-2.5	2.5T-7.5L 2.5T-8.5L	
	P4		0 -4 -5	+2.5	-2.5	2.5T-6.5L 2.5T-7.5L	
外圈旋转负荷	低速/高速轻负荷	P5	0 -5.1	+2.5	-2.5	2.5T-7.6L	压气机 带轮
		P4	0 -5 -6	+2.5	-2.5	2.5T-7.5L 2.5T-8.5L	
		P4	0 -4 -5	+2.5	-2.5	2.5T-6.5L 2.5T-7.5L	

注：1) 代号T与L分别表示过盈与间隙配合
2) P5级与P4级的轴承的单一平面内平均外径的偏差以及配合一栏的上行数字适用于D<18mm，下行数字适用于18<D<30mm

11 轴承材料

11.1 套圈及滚动体的材料

套圈及滚动体通常使用高碳铬轴承钢GCr15(表11.1)。
GCr15的化学成份，在世界各国已规格化。如，美国AISI 52100、德国DIN 100Cr6、日本SUJ2

根据特殊用途，还使用耐腐蚀性好的不锈钢。化学成分见(表11.2)。

表11.1高碳铬轴承钢

Table 11.1 High Carbon Chromium Bearing Steel

规格 Specification	牌号 Trademark	化学成分% Chemical composition(%)						
		C	Si	Mn	Cr	S	P	Mo
GB/T 18254	Gcr15	0.95~1.05	0.15~0.35	0.25~0.45	1.40~1.65	≤0.025	≤0.025	—
JIS G 4805	SUJ2	0.95~1.10	0.15~0.35	≤0.50	1.30~1.60	≤0.025	≤0.025	≤0.08
ASTM A295	52100	0.98~1.10	0.15~0.35	0.25~0.45	1.30~1.60	≤0.025	≤0.025	≤0.10

Table 10.7 Fits of Precision Miniature . Small Diameter Ball Bearing (d<10mm) with Shafts

Load conditions	Bearing precision class	Deviation of mean bore diameter Δd_{mp}		Deviation of shaft diameter		Fits ¹⁾	Examples
		Max	Min	Max	Min		
		Inner ring rotating load	Middle/high speed, light and normal load	P5	0 -5.1 -5		
P4	0 -5.1 -4			+2.5	-2.5	7.6-2.5L 6.5-2.5L	
Low speed and light load	P5		0 -5.1 -5	-2.5	-7.5	2.6-7.5L 2.5-7.5L	Universal frames for gyroscope Synchronizer Servo motors Floppy disk driver
	P4		0 -5.1 -4	-2.5	-7.5	2.6-7.5L 1.5-7.5L	
Outer ring rotating load	Low/high speed and light load	P5	0 -5.1 -5	-2.5	-7.5	2.6-7.5L 2.5-7.5L	Impaction wheel The leading type wheel Linear actuator
		P4	0 -5.1 -4	-2.5	-7.5	2.6-7.5L 1.5-7.5L	

[Note]: T and L means tight and loose fit

Table 10.8 Fits of Precision Miniature .Small Diameter Ball Bearing (d<30mm) with Housings

Load conditions	Bearing precision class	Deviation of mean bore diameter Δd_{mp}		The deviation of the shell aperture		Fits ¹⁾	Examples
		Max	Min	Max	Min		
		Inner ring rotating load	Middle/high speed, light and normal loads	P5	0 -5.1		
P4	0 -5 -6			+5	0	0-10L 0-11L	
P4	0 -4 -5			+5	0	0-9L 0-10L	
Low speed and light load	P5		0 -5.1	+2.5	-2.5	2.5T-7.6L 2.5T-7.5L	Universal frames for gyroscope Synchronizer Servo motors Floppy disk driver
	P4		0 -5 -6	+2.5	-2.5	2.5T-7.5L 2.5T-8.5L	
	P4		0 -4 -5	+2.5	-2.5	2.5T-6.5L 2.5T-7.5L	
Outer ring rotating load	Low-high speed and light load	P5	0 -5.1	+2.5	-2.5	2.5T-7.6L	Impaction wheel The leading type wheel
		P4	0 -5 -6	+2.5	-2.5	2.5T-7.5L 2.5T-8.5L	
		P4	0 -4 -5	+2.5	-2.5	2.5T-6.5L 2.5T-7.5L	

Note: 1) T and L indicate tight and loose fit.
2) The upper limit of Δd_{mp} and fits of P5 and P4 bearings applies to D<18mm and the lower limit applies to 18<D<30mm.

表11.2滚动轴承用不锈钢的化学成分

Table 11.2 The Chemical Composition of Stainless Steel for Rolling Bearing

规格 Specification	牌号 Trademark	化学成分% Chemical composition(%)						
		C	Si	Mn	Cr	P	S	Mo
GB 3086	9Cr18	0.95~1.00	≤0.80	≤0.80	17.00~19.00	≤0.035	≤0.030	—
JISG 4303	SUS 440C	0.95~1.20	≤1.00	≤1.00	16.00~18.00	≤0.040	≤0.030	≤0.075

11.2 保持架材料

11.2 Cage Material

11.2.1 冲压保持架

11.2.1 The pressed cage

冲压保持架的材料，使用低碳碳素钢。

The pressed cage material is low carbon steel

表11.3保持架用钢板及碳素钢的化学成分

Table 11.3 The Chemical Composition of Steel Sheet and Carbon Steel for Bearing Cage

区分 Difference	规格 Specification	牌号 Trademark	化学成分 Chemical composition(%)				
			C	Si	Mn	P	S
冲压保持架用钢板 Steelsheet for pressed cage	JISG 3141	SPCC	≤0.12	—	≤0.50	≤0.04	≤0.045

11.3.2 尼龙保持架

11.3.2 Nylon cage

表11.4尼龙保持架的技术要求

Table 11.4 The Technical Requirements for Nylon Cage

序号 Number	项 目Description	PA66-GF25	PA66-GF30	PA66-GF15	PA66-GF15	
1	外观 Appearance	细粒状、无明显色差、无焦粒。 Fine granulation, without obvious color difference, without color particle.				
2	熔点(°C) It(°C) Melting point(°C)	≥255				
3	密度 (g/cm ³) Density (g/cm ³)	1.32	1.36	1.23	1.14	
4	吸水性 (%) Water absorbing rate(%)	≤1	≤1	≤1	≤1.5	
5	模塑收缩率 (%) Corstriction rate(%)	0.55	0.50	0.75	1.5~2.5	
6	拉伸强度 (Mpa) Tensile strength(MPa)	≤150	≤160	≤110	≤70	
7	冲击强度 (KJ/m ²) Impact strength (KJ/m ²)	≥42	≥50	≥35	≥60	
8	缺口冲击强度 (KJ/m ²)Notch impact strength)(KJ/m ²)	≥7	≥8	≥6	≥5	
9	球压痕硬度 (MPa)Ballindentation hardness(Mpa)	≥200	≥210	≥170	≥130	
10	弯曲弹性模量 (GPa)Flexible mOdule(GPa)	≥6	≥7	≥5	≥2.5	
11	热变形温度 (1.8MPa)°CThermaldefBrmation temperature[(1.8MPa)°C]	≥240	≥240	≥240	≥70	
12	线膨胀系数 (10. 5/°C)Linear expansion coefficient(1 0 ⁵ /°C)	2~3	1.5~2	3~4	7~10	
13	使用温度范围(°C) Working temperature range(°C)	-40~120	-40~120	-40~110	-40~90	
14	耐热老化性能 Heat aging properties	a. 拉伸强度 (MPa)Tensile strength (MPa)	≥110	—	—	—
		b. 冲击强度 (KJ/m ²) Impact strength(KJ/m ²)	≥15	—	—	—
		缺口冲击强度 (KJ/m ²) Notch imDact strengt—(KJ/m ²)	≥6	—	—	—

注：PA66-GF25、PA66-GF30、PA66-Gf15的玻璃纤维含量分别是：25%、30%、15%。
Note. For PA66-GF25、PA66-GF30、PA66-GF15, the content of glass fibre is respectively, 25%, 30% and 15%.

12 轴与轴座设计

设计轴与轴承座时应注意以下事项。

- 1) 轴应短而粗以减小轴的变形或弯曲；
- 2) 轴承座结构成具有足够的刚性以减小负荷引起的变形；
- 3) 轴及轴承座的配合面应达到所需的精度与粗糙度；
- 4) 圆角半径(r_a)应小于轴承倒角尺寸(参照图12.1、图12.2)。

注：一般做成简单的圆弧形(参照图12.1)；磨削轴可设退刀槽(参照图12.2)。

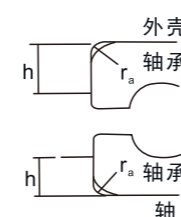


图12.1圆角半径

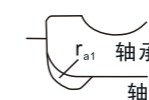


图12.2圆角退刀槽

- 5) 为便于轴承的拆卸，挡肩(高度h)直径应小于内圈外径，或大于外圈内径(图12.3、表12.1)。
- 6) 圆角半径需大于轴承倒角尺寸，或挡肩高度需减时，应在内圈与轴肩，或外圈与轴承座孔肩之间加垫圈。

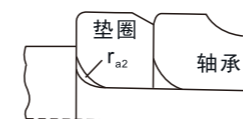


图12.3 加垫圈事例

- 7) 轴上的轴承固定用螺孔或锁紧螺母用螺纹应尽量与轴端垂直，螺纹旋向与轴的旋转方向相反为宜。
- 8) 剖分型轴承座的对合面应细心加工，并在其内侧发避让倒角。

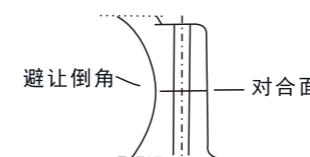


图12.4 对合面的避让倒角

12.1 轴与轴承座的精度与表面粗糙度

对于一般使用条件，轴及轴承座的配合面采用经车或精镗加工即可，但在旋转跳动及噪声要求严格，或负荷条件恶劣时，需要采用磨削加工。

一般使用条件，轴及轴承座的推荐精度与表面粗糙度如表12.1所示。

12 DESING OF SHAFTS AND HOUSING

Design of shafts and housing should notice following instructions:

- 1) It should select short and thick shafts;
- 2) Housing structure should have enough rigidity;
- 3) The matching surface of shaft and housing should be reached accuracy and roughness requirement;
- 4) Fillet radius should be less than chamfer dimension. (Refer to Fig 12.1, 12.2)

Remarks: A simple arc is usually manufactured (Refer to Fig 12 .1) Grinding shaft can be with relief groove(Refer to Fig 12 .2)

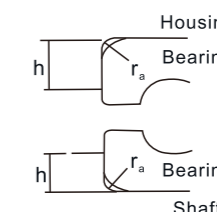


Fig12.1 Fillet Radius



Fig12.2 Relief Groove

- 5) In order to dismount easily, the shoulder height diameter should be less than inner ring outside diameter, or be more than outer ring bore diameter.
- 6) Fillet radius should be more than bearing chamfer dimension, or adding lock washer between inner rings and shaft shoulder or outer ring and housing boreshoulder.

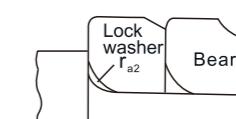


Fig.12.3 Example for Adding Lock Washer

- 7) Use screw or locknut to fix bearing on shaft let screw thread to plumb with shaft. The rotating direction between screw thread and shaft operating direction should opposite.
- 8) The connecting surface at split bearing housing should be carefully machined, and a chamfer at connecting surface should be set up.

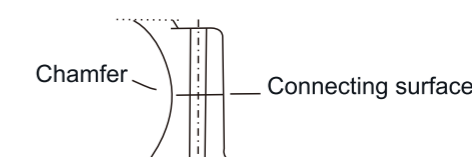


Fig12.4 Chamfer for Connecting Surface

12.1 Accuracy and Surface Finish of Shafts and Housings

For normal operating conditions, a machined finish or fine bored finish is sufficient for the fitting surface. However, a ground finish is necessary for applications where vibration and noise must be low or where heavy loads are applied.

The accuracy and surface finish of shafts and housings are listed in Table 12.1 for normal operating conditions.

表12.1轴与轴承座的推荐精度与表面粗糙度

项目	轴承的精度等级	轴	轴承座孔
圆度公差	0级、6级	IT3-IT4	IT4-IT5
	5级、4级	IT2-IT3	IT2-IT3
圆柱度公差	0级、6级	IT3-IT4	IT4-IT5
	5级、4级	IT2-IT3	IT2-IT3
挡肩的端面跳动	0级、6级	IT3	IT3-IT4
	5级、4级	IT3	IT3
配合面的粗糙度Ra	小型轴承	0.8	1.6
	大型轴承	1.6	3.2

12.2轴安装的相关尺寸

轴承安装的相关尺寸是指将轴承安装在轴上或轴承座内时所需的（轴或轴承座）圆角半径和挡肩高度等尺寸见（图12.5）。

标准的安装相关尺寸如表12.2所示（各类轴承安装的相关尺寸参照相应的轴承尺寸表）。

此外，退刀槽示例见（图12.6、表12.3）。

表12.2轴及轴承座的圆角半径与向心轴承所需的挡肩高度

内圈或外圈的倒角尺寸 r (最小)	轴或外壳		
	圆角半径 ra (最大)	挡肩高度h(最小)	
		一般 ¹⁾ 场合	特殊 ²⁾ 场合
0.05	0.05	0.3	0.3
0.08	0.08	0.3	0.3
0.1	0.1	0.4	0.4
0.15	0.15	0.6	0.6
0.2	0.2	0.8	0.8
0.3	0.3	1.25	1
0.5	0.5	1.75	1.5
0.6	0.6	2.25	2
0.8	0.8	2.75	2.5
1	1	2.75	2.5
1.1	1	3.5	3.25
1.5	1.5	4.25	4
2	2	5	4.5
2.1	2	6	5.5
2.5	2	6	5.5
3	2.5	7	6.5
4	4	9	8
5	5	11	10
6	5	14	12
7.5	6	18	16
9.5	8	22	20
12	10	27	24
15	12	32	29
19	15	42	38

注：

- 1) 轴向负荷大时，挡肩高度必须大于表中数值；
- 2) 适用于小轴向负荷的场合；表中数值不适用于圆锥滚子轴承，角接触球轴承和调心滚子轴承。

注：圆角半径也适用于推力轴承。

Table 12.1 Accuracy and Roughness of Shaft and Housing

Items	Bearing Precision class	Shaft	Housing bore
Roundness tolerance	P0.P6	IT3-IT4	IT4-IT5
	P5.P4	IT2-IT3	IT2-IT3
Cylindricity tolerance	P0.P6	IT3-IT4	IT4-IT5
	P5.P4	IT2-IT3	IT2-IT3
Shoulder runout	P0.P6	IT3	IT3-IT4
	P5.P4	IT3	IT3
Roughness of matching surfaces Ra	Small bearing,	0.8	1.6
	large bearing	1.6	3.2

12.2 Surrounding Dimensions

The bearing surrounding dimensions is the dimensions for fillet radius and shoulder height where the shaft or housing contact with the surface of a bearing (See in Fig.12.5). The surrounding dimensions are shown in Tab 12.2 (Other correlative dimensions referring to other Table). In addition, shaft undercut dimensions are shown as Fig. 12.6 and Tab.12.3

Table 12.2 Minimum Shoulder Heights for Applications with Metric Series Radial Bearings

Chamfer dimension for inner ring or outer ring	Shaft or housing		
	Fillet radius ra (max)	Shoulder height h(min)	
		General applications ¹⁾	Special applications ²⁾
0.05	0.05	0.3	0.3
0.08	0.08	0.3	0.3
0.1	0.1	0.4	0.4
0.15	0.15	0.6	0.6
0.2	0.2	0.8	0.8
0.3	0.3	1.25	1
0.5	0.5	1.75	1.5
0.6	0.6	2.25	2
0.8	0.8	2.75	2.5
1	1	2.75	2.5
1.1	1	3.5	3.25
1.5	1.5	4.25	4
2	2	5	4.5
2.1	2	6	5.5
2.5	2	6	5.5
3	2.5	7	6.5
4	4	9	8
5	5	11	10
6	5	14	12
7.5	6	18	16
9.5	8	22	20
12	10	27	24
15	12	32	29
19	15	42	38

Notes:

- 1) When heavy axial loads are applied, the shoulder height must be sufficiently higher than the values listed;
- 2) It is only applicable for light axial load. This table is not applied for tapered roller bearings, angular contact ball bearings and spherical roller bearings.

Remark: The fillet radius of the chamfer is also applicable to thrust bearings.

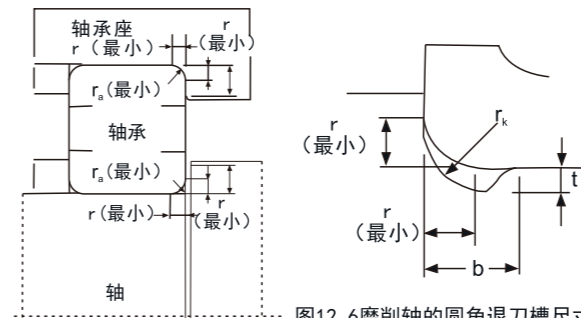


图12.5

表12.3 单位：毫米

内圆倒角尺寸 r (最小)	退刀槽尺寸		
	t	r _g	b
1	0.2	0.3	2
1.1	0.3	0.5	2.4
1.5	0.4	2	3.2
2	0.5	2.5	4
2.1	0.5	2.5	4
3	0.5	3	4.7
4	0.5	4	5.9
5	0.6	5	7.4
6	0.6	6	8.6
7.5	0.6	7	10

12.3轴的设计示例（轴承的轴向定位）

将轴承安装在轴上时，必须考虑轴向定位的方法，表12.4为圆柱孔轴承的轴向定位例。

12.4轴承配合面和挡肩的加工精度

圆柱型的轴颈和轴承座孔，推力轴承套圈的配合面和支承面（如轴和轴承座的挡肩等）的精度，必须与所用轴承精度相配合。以下给出的尺寸公差、形位公差和旋转精度的参考值，在加工配合面和挡肩时，必须严格遵守。

表12.4 圆柱孔轴承的轴向定位

(a) 轴用螺母	(b) 轴端挡盖	(c) 定位挡圈
一般用止动垫防止螺母松动。对于圆锥滚子轴承或角接触球轴承，当配合较松时，如右图所示，可在轴承与止动垫之间加进一定厚度的垫圈再锁紧	轴端开有螺孔	用于安装空间受限制以及需要简化轴的机械加工时

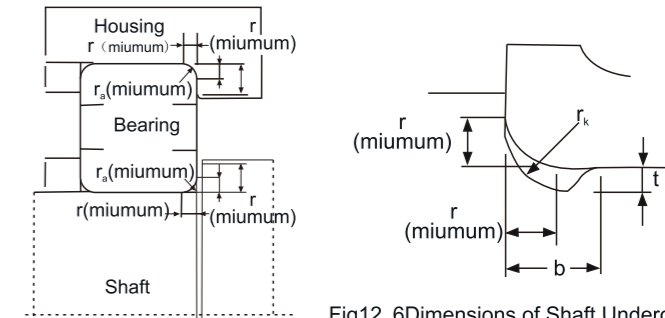


图12.6

Table 12.3 Unit:mm

Chamfer dimensions of inner ring r(min)	Undercut dimensions		
	t	r _g	b
1	0.2	0.3	2
1.1	0.3	0.5	2.4
1.5	0.4	2	3.2
2	0.5	2.5	4
2.1	0.5	2.5	4
3	0.5	3	4.7
4	0.5	4	5.9
5	0.6	5	7.4
6	0.6	6	8.6
7.5	0.6	7	10

12.3 Example of Design Shafts (Axial Position of Bearing)

It should be considered the axial position methods when bearing is mounted in shaft. Example of cylindrical bore bearing of axial position as Tab 12.4

12.4 Fitting Surface and Processing Precision

The precision of cylindrical journal and bearing housing bore, fitting surface and supporting surface of rings of thrust bearing, such as shaft and shoulder of bearing housing etc., must comply with the bearing precision. Please refer to the dimensional tolerance, geometric tolerance and running accuracy showed below. It should be strictly followed when we process the fitting surface and shoulder.

Table 12.4 Cylindrical Bore Bearing of Axial Position

(a) Locknut	(b) Locking clamps	(c) Snap ring
For tapered roller bearings and angular-contact ball bearings, using lock washer to prevent nut loose, it could add more lock washers and then locked.	Locking clamps with screw hole	Applied for limited mounting space and simple machining

12.4.1 尺寸公差

对于普通级公差的轴承，圆柱型轴颈和轴承座孔的尺寸精度至少必须达到公差级IT6和IT7。当使用紧定套和拆卸套时，轴颈可以采用较宽的直径公差，如IT9或IT10见（表12.4.1）。表12.4.2给出了根据ISO286标准公差等级的IT的数值。使用更高精度的轴承时，应采用相应更高的精度等级。

表12.4.1 轴公差一配用轴套的轴承

公称值 大于 d(mm)	至	直径公差和形状公差					
		公差h9(μm)		公差h10(μm)			
		上偏差	下偏差	最大	上偏差	下偏差	最大
10	10	0	-43	8	0	-70	18
18	30	0	-52	9	0	-84	21
30	50	0	-62	11	0	-100	25
50	80	0	-74	13	0	-120	30
80	120	0	-87	15	0	-140	35

1) 推荐值应为IT 5/2或IT7/2，因为公差带t是半径，而在上表中，值是相对于标称轴直径的，因此没有折半。

12.4.2 圆柱度公差

按ISO1101规定的圆柱度公差，根据应用的不同要求，应比规定的尺寸公差高1到两个IT等级。如轴颈的尺寸公差是按m6加工，其形位公差则应为IT5或IT4。在表12.4.2中给出了不同轴承公差等级的圆柱度公差和总跳动公差的参考值。

12.4.1 Dimensional tolerance

For the bearings in ordinary class, the dimensional tolerance of cylindrical journal and bearing housing bore should reach IT6 and IT7 Or above. When adapter sleeve and withdrawal sleeve are used, wider range of diameter tolerance can be adopted on journal, as shown in IT9 Or IT10 (Table 12.4.1). IT values according to standard tolerance grade in ISO286 are shown in Table 12.4.2. When bearings with higher precision are used, higher precision grade should be adopted correspondingly.

Table 12.4.1 Tolerance of Shaft Suitable for Shaft Sleeve Bearings

Shaft diameter		Tolerance of diameter and form					
Nominal diameter over d(mm)	Incl	Tolerance h9(μm)		Tolerance h10(μm)			
		Upper limit	Lower limit	IT5 ¹⁾ Max.	Upper limit	Lower limit	IT7 ¹⁾ Max.
10	10	0	-43	8	0	-70	18
18	30	0	-52	9	0	-84	21
30	50	0	-62	11	0	-100	25
50	80	0	-74	13	0	-120	30
80	120	0	-87	15	0	-140	35

1) The recommended values should be IT5/2 and IT7/2 because the tolerance range t is calculated in radius, relative to the nominal diameter of shaft.

12.4.2 Cylindricity tolerance

The cylindricity tolerance stipulated in ISO1101 should be one or two IT class higher than the prescribed dimensional tolerance concerning different application requirements, e.g. when the dimensional tolerance of journal is processed with m6 class, the form tolerance should be IT5 Or IT4. The cylindricity tolerance and total run-out tolerance in different tolerance grades are listed in Table 12.4.2.

表12.4.2 ISO标准公差等级（用于长度、宽度、直径等）

公称尺寸 d (mm)	至	公差等级最大 (μm)											
		IT1	IT2	IT3	IT4	IT5	IT6	IT7	IT8	IT9	IT10	IT11	IT12
1	3	0.8	1.2	2	3	4	6	10	14	25	40	60	100
3	6	1	1.5	2.5	4	5	8	12	18	30	48	75	120
6	10	10	1.5	2.5	4	6	9	15	22	36	58	90	150
10	18	1.2	2	3	5	8	11	18	27	43	70	110	180
18	30	1.5	2.5	4	6	9	13	21	33	52	84	130	210
30	50	1.5	2.5	4	7	11	16	25	39	62	100	160	250
50	80	2	3	5	8	13	19	30	46	74	120	190	300
80	120	2.5	4	6	10	15	22	35	54	87	140	220	350

12.4.3 垂直度公差

根据ISO1101对挡肩垂直度公差的规定，应至少比圆柱形轴颈公差高一个IT等级。对于推力轴承套圈的配合面，垂直度公差不应低于IT5。表12.4.3给出了垂直度公差和轴向跳动公差的参考值。

表12.4.3轴颈和轴承座孔的形位公差

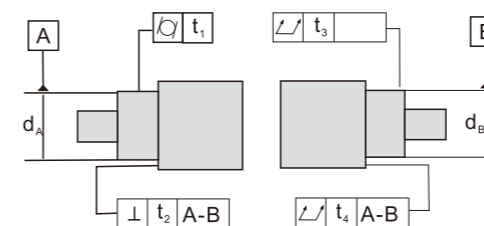


表12.4.3轴颈和轴承座孔的形位公差

表面特性	特性符号	公差带	轴承的公差等级 ¹⁾			
			普通级	LCN P6	P5	
圆柱的 配合面	圆柱度	\bigcirc t ₁	IT5/2	IT4/2	IT3/2	IT2/2
	总径向 跳动	\bigcirc t ₃	IT5/2	IT4/2	IT3/2	IT2/2
平面 挡肩	矩形度	\perp t ₂	IT5	IT4	IT3	IT2
	总轴向 跳动	\bigcirc t ₄	IT5	IT4	IT3	IT2

说明：

用于正常需求 用于在旋转精度或支承面有特殊要求的场合
对于高精度的轴承（如P4级或以上），请与MOGB联系咨询。

Table 12.4.2 Tolerance Grades in ISO Standard (Used in Length, Width and Diameter etc.)

Nominal dimension	至	Tolerance grade max. (μm)											
		IT1	IT2	IT3	IT4	IT5	IT6	IT7	IT8	IT9	IT10	IT11	IT12
1	3	0.8	1.2	2	3	4	6	10	14	25	40	60	100
3	6	1	1.5	2.5	4	5	8	12	18	30	48	75	120
6	10	10	1.5	2.5	4	6	9	15	22	36	58	90	150
10	18	1.2	2	3	5	8	11	18	27	43	70	110	180
18	30	1.5	2.5	4	6	9	13	21	33	52	84	130	210
30	50	1.5	2.5	4	7	11	16	25	39	62	100	160	250
50	80	2	3	5	8	13	19	30	46	74	120	190	300
80	120	2.5	4	6	10	15	22	35	54	87	140	220	350

12.4.3 Verticality tolerance

The verticality tolerance of shoulder stipulated in ISO1101 should be at least one IT class higher than cylindrical journal tolerance. With regard to fitting surface of rings of thrust bearing, the verticality tolerance ought not to be lower than IT5. Table 12.4.3 below shows the reference values of verticality tolerance and axial run-out tolerance.

Table 12.4.3 Geometric Tolerance of Journal and Bearing Housing Bore

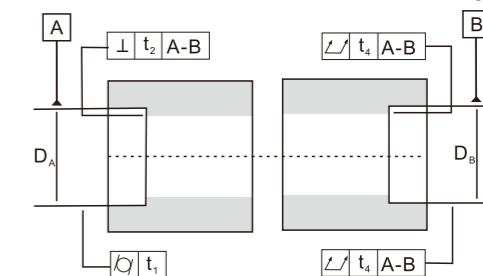


Table 12.4.3 Geometric Tolerance of Journal and Bearing Housing Bore

Surface characteristics	Symbols	Tolerance range	Tolerance range			
			Ordinary grade	LCN P6	P5	
Cylindrical fitting surface	Cylindrical	\bigcirc t ₁	IT5/2	IT4/2	IT3/2	IT2/2
	Total radial run-out	\bigcirc t ₃	IT5/2	IT4/2	IT3/2	IT2/2
Plane shoulder	Squareness	\perp t ₂	IT5	IT4	IT3	IT2
	Total axial run-out	\bigcirc t ₄	IT5	IT4	IT3	IT2

Remarks:

Adopted in ordinary requirement 用于正常需求
Adopted in special requirements on running accuracy or supporting surface 用于在旋转精度或支承面有特殊要求的场合
Please contact MOGB regarding high precision bearing(P4 class or above).

13 轴承的使用

13.1 使用时的注意事项

滚动轴承是精密部件，其使用须慎重进行。即使高性能的轴承，如果使用不当，也不会得到预期的效果。有关轴承的使用注意事项如下。

(1) 保持轴承及其周围清洁

即使是肉眼看不到的尘埃，也会给轴承带来不良影响。所以，要保持周围清洁，避免尘埃不致侵入轴承。

(2) 小心谨慎地使用

在使用中如果使轴承受到强烈冲击，会产生伤痕甚至压痕，成为失效的原因。严重时，会导致轴承零部件出现裂缝、断裂，所以应特别注意。

(3) 使用恰当的作业工具

避免以现有的工具代替，必须使用恰当的工具。

(4) 要注意轴承的锈蚀

操作时，手汗会导致生锈，最好戴上手套。

(5) 使用者应熟悉轴承

(6) 制定轴承使用时的操作规范

- 轴承的保管
- 轴承及其刷边的清洁
- 安装部位的尺寸与加工质量的检验
- 安装作业
- 安装后的检查
- 拆卸作业
- 维护保养（定期检查）
- 润滑剂的补充

13.2 轴承的保管

轴承在出厂时均涂有适量的防锈油并用防锈纸包装，只要该包装不被破坏，轴承的质最将得到保证。

但长期存放时，应在湿度低于65%，温度为20°C左右的条件下，存放存高于地面30cm的货架为宜。

另外，保管场所应避免阳光直射或与寒冷的墙壁接触。

13.3 轴承的安装

13.3.1 安装前注意事项

1) 轴承的准备

由于轴承经过防锈处理并加以包装，因此不到安装前不要打开包装。

另外，轴承上涂抹的防锈油具有良好的润滑能，对于一般用途的轴承或充填润滑脂的轴承，可不必清洗直接使用，但对于仪表用轴承或用于高速旋转的轴承，应用清洁的清洗油将防锈油洗去，这时轴承容易生锈，不可长时间放置。

2) 轴与外壳的检验

清洗轴与轴承座，应确认无伤痕或机械加上留下的毛刺。轴承座内禁止有研磨剂(SiC、Al₂O₃等)型砂，切屑等。

其次检验轴与轴承座的尺寸、形状和加工质量是否与图纸符合。

13 BEARING HANDLING

13.1 Some Tips on Mounting & Dismounting

Rolling bearing is a precise part. Therefore it should be handled carefully. No matter how high performance the bearing has, it can not be obtained by improper handle. The followings are the points for attention to handle bearings.

(1) Clean the bearing and its surrounding

It is harmful to the bearing that ingress of tiny dust which can not be seen by the naked eyes. Therefore it should always clean the surrounding in order to prevent the bearing from contamination .

(2) Handle bearing carefully

Indentation can easily be produced out Of strong impact to the bearing in handling and become the cause of failure. It will even result in cracks & fractures. Therefore special caution should be given to its handling.

(3) Use the appropriate operating tool

It shall be obliged to use proper tool instead of general one.

(4) Be careful to the rust corrosion of the bearings

Perspiration on the hands will cause rust in operating the bearings. Therefore your hands should be cleanly washed and dried before handling. You'd better wear gloves in doing the work.

(5) Handler should be familiar with bearing

(6) Establish bearing handling procedures

- Bearing storage
- Bearing and surrounding cleaning
- Surrounding dimension inspection
- Mounting procedures
- Inspection after mounting
- Mounting handling
- Maintenance
- Lubricant replenish

13.2 Bearing Storage

Before leaving the factory, the bearing is sprayed proper rust-proof oil and packed with rust-proof paper. The quality of bearing is guaranteed, if the packing is not broken.

For long-term storage, if the humidity less than 65% and the temperature about 20°C , it should storage on shelf which is higher 30cm than ground.

In addition, storage location should avoid direct sunlight or contacting with cold wall.

13.3 Bearing Mounting

13.3.1 Precautions for proper mounting of bearing

1) Bearing preparation

Bearing sprayed with rust-proof oil and packed with rust-proof paper should not be unpacked until before mounting. In addition, spray anti-corrosion oil on bearing have good lubrication function. For general purpose, just directly mount bearing or grease filled bearings without cleaning. However, bearing for instrument or high speed rotating must be cleaned with clean filtered oil in order to remove the rust-proof oil. At that time, the bearings are easy to rust could not open long term.

2) Inspection of shafts and housings

Clean shaft and housing, and confirm no scratched or machining burrs, no abrasive and cutting piece in housing.

Secondly, the shaft and housing dimension, form and machining quality should be ensured to comply with drawing be inspected.

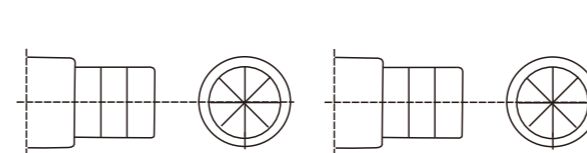


图13.1 轴径的测量位置

Fig.13.1 Measuring Location for Shaft Diameter

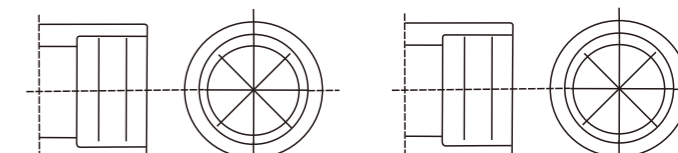


图13.2 轴承座孔径的测量位置

Fig.13.2 Measuring Location for Housing Bore Diameter

如图13.1和图13.2所示，分几处测量轴径与轴承座孔径。还要认真检验轴与轴承座的圆角尺寸及挡肩的垂直度。

安装轴承前，在检验合格的轴与外壳的各配合面涂抹机械油。

13.3.2 轴承的预紧

安装轴承时，应注意，当预紧超过某既定的最佳值时，刚性只能有限地提高。因为这时随着轴承的运转，摩擦加剧，产生的热量也将增加。如果有附加负荷并且长时间的作用下，轴承寿命将大大降低。从图13.3中可以看出轴承寿命与预紧 / 游隙之间的关系。由于过度的预紧，对轴承安装运行的可靠性有很大的影响。

确定适当的预负荷涉及到复杂的计算，因此需要计算预负荷时，请联系MOGB公司。

此外，在调整轴承安装时的预紧时，无论预紧量是通过计算还是根据经验而定，必须将其偏差控制在一定范围内。

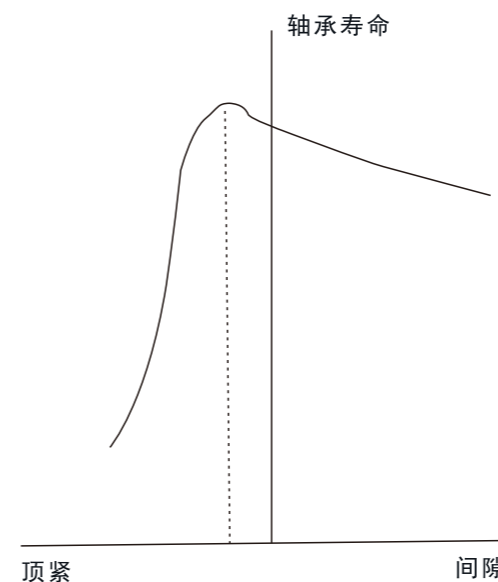


图13.3

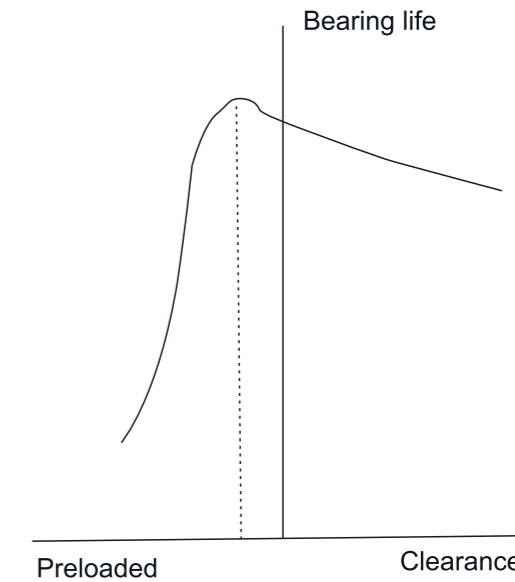


Fig.13.3

常用润滑脂的明细表
A DETAIL LIST OF THE COMMONLY-USED LUBRICATING GREASE

常用润滑脂的明细表
A DETAIL LIST OF THE COMMONLY-USED LUBRICATING GREASE

MOGB油脂一览表 MOGB GREASE DATA SHEET								
制造厂 Maker	牌号 Brand	增稠剂 Viscosity	基油 Base oil	滴点 Drop point °C	稠度 Consistency	使用 温度范围 Operating temperature range °C	选用原则 Selection criteria	NMB 代码 Code
Exxon	Beacon325	锂基 (Lithium)	双酯 (Diester)	193	290	-60~+120	低温脂 low-temperature grease	LG20
	Ac205	钠基 (Nathium)	矿物 (Mineral)			-25~+120	常温脂 normal temperature grease	
	Andok B	钠基 (Nathium)	矿物 (Mineral)	260	280	-40~+120	常温脂 normal temperature grease	LG38
	Andok 260	钠基 (Nathium)	矿物 (Mineral)	200	250	-30~+150	常温脂 normal temperature grease	LG71
	Arapen RB300	锂基 (Lithium)	矿物 (Mineral)	200	250	-30~+100	常温脂 normal temperature grease	
	*Polyrex EM	双尿素 (Diurea)	矿物 (Mineral)	260	288	-40~+180	高温低噪音 high temperature low noise	
	*Polyrex Ep2	尿素 (Urea)	矿物 (Mineral)	280	280	-40~+180	高温低噪音 high temperature low noise	
	UNIREX N2	锂皂复合基 (Lithium Comple)	矿物 (Mineral)	250	280	-40~+180	高温低噪音 high temperature low noise	
	UNIREX N3	锂皂复合基 (Lithium Comple)	矿物 (Mineral)	250	235	-40~+180	高温低噪音 high temperature low noise	
	Kyodo Yushi	Multemp PS2	锂基 (Lithium)	双酯 (Diester)	189	280	-50~+110	低温脂 low-temperature grease
*Multemp SRL		锂基 (Lithium)	酯(Ester)	191	245	-40~+150	低噪声脂 low noise grease	LY121
Multemp SC-A		尿素 (Urea)		≥260	280	0~+160	常温脂 normal temperature grease	
Multemp Et150		尿素 (Urea)	矿物 (Mineral)	≥260	280	-10~+160	常温脂 normal temperature grease	
Oneluba		锂基 (Lithium)	双酯-矿物 (Diester Mineral)	198	270	-10~+110	常温脂 normal temperature grease	
Adrex		锂基 (Lithium)	矿物 (Mineral)	198	300	-10~+120	常温脂 normal temperature grease	
Parmax			矿物 (Mineral)	180	300	-10~+120	常温脂 normal temperature grease	
Emalube 1130		尿素 (Urea)	矿物 (Mineral)	≥260	300	-10~+130	常温脂 normal temperature grease	

(注: *表示MOGB常用油脂) NOTE: *indicates the commonly-used grease of MOGB.

MOGB油脂一览表 MOGB GREASE DATA SHEET								
制造厂 Maker	牌号 Brand	增稠剂 Viscosity	基油 Base oil	滴点 Drop point °C	稠度 Consistency	使用 温度范围 Operating temperature range °C	选用原则 Selection criteria	NMB 代码 Code
kyodo Yushi	Unilube DL1	锂基 (Lithium)	矿物 (Mineral)	185	332	-10~+110	常温脂 normal temperature grease	
	Alumix HD1		矿物 (Mineral)	247	335	0~+120	常温脂 normal temperature grease	
	Multemp LTS	锂基 (Lithium)	酯(Ester)	250	201	-60~+130	低温脂 Low-temperature grease	
	Multemp SRH	锂基 (Lithium)	酯(Ester)	250	201	-40~+150	低温脂 Low-temperature grease	LY530
	*Multemp SB-M	双尿素 (Diurea)	合成油 (Synthetic oil)	220	260	-40~+200	高温高速脂 high temperature high speed grease	
	Multem SC-C	双尿素 (Diurea)	合成油 (Synthetic oil)	280	300	-40~+200	高温水泵脂 high temperature water-pump grease	
	* ET-K	双尿素 (Diurea)	合成油 / 脂 (Synthetic Oil/ Grease)	260	300	-40~+200	高温高速交流发电机脂 high temperature high speed alternators grease	
	ET-100K		合成油 (Synthetic oil)	260	280	-40~+200	高温脂 high temperature grease	
	ET-R		合成油 (Synthetic oil)	260	280	-40~+250	高温、低温力矩好 high temperature grease, low temperature torque good	
	Multemp FF-SL	聚四氟乙烯 (PTFE)	氟化油 (Fluoinated)		300	-30~+250	高温、抗蚀脂 high temperature, corrosion resisting grease	
	Multemp FF-RM	聚四氟乙烯 (PTFE)	氟化油 (Fluoinated)		290	-30~+250	高温、抗蚀脂 high temperature, corrosion resisting grease	
	Super N	聚脲	合成油 (Synthetic oil)	255	260	-40~+200	高温脂 high temperature grease	
	Multemp 8158	芳香族	酯(Ester)	260	310-340	-45~+200	高温高负荷脂 high temperature high load grease	
	* Multemp LRL	锂基 (Lithium)	多元醇酯	205	238	-40~+150	高温低噪声 high temperature low noise	
Klubber	Staburags NBU12	钡基 (Barium)	双酯-矿物 (Diester Mineral)	220	270	-35~+150	常温脂 normal temperature grease	
	Isoflex NBU15	钡基 (Barium)	双酯-矿物 (Diester Mineral)	220	280	-30~+130	常温脂 normal temperature grease	
	* Asonic GLY32	锂基 (Lithium)	合成 (Synthetic)	190	265-295	-50~+140	低温脂 low-temperature grease	
	* Asonic GHY72	Polyhamstoff	酯-矿物 (Ester Mineral)	250	250-280	-40~+180	高温低噪声 high temperature low noise	

(注: *表示MOGB常用油脂) NOTE: *indicates the commonly-used grease of MOGB.

常用润滑脂的明细表
A DETAIL LIST OF THE COMMONLY-USED LUBRICATING GREASE

常用润滑脂的明细表
A DETAIL LIST OF THE COMMONLY-USED LUBRICATING GREASE

MOGB油脂一览表 MOGB GREASE DATA SHEET								
制造厂 Maker	牌号 Brand	增稠剂 Viscosity	基油 Base oil	滴点 Drop point °C	稠度 Consistency	使用 温度范围 Operating temperature range °C	选用原则 Selection criteria	NMB 代码 Code
Kluber	Isoflex Super LDS18	锂基 (Lithium)	双酯 (Diester)	190	280	-60~+130	低温脂 low-temperature grease	LY218
	Isoflex Super TEL	锂基 (Lithium)	脂-矿物 (Ester Mineral)			-65~+70	低温脂 low-temperature grease	
	Isoflex LDS18 Special A	锂基 (Lithium)	双酯 (Diester)	190	280	-60~+130	低温脂 low-temperature grease	
	Isoflex PDB38 CX100	锂基 (Lithium)	酯(Ester)			-70~+120	低温脂 low-temperature grease	
	Isoflex Topas NB52	钡基 (Barium)	合成碳氢 (Synthetic hydrocarbon)	240	280	-60~+170	高、低温脂 high-low temperature grease	
	*Barrierta L55/2	聚四氟乙烯 (PTFE)	氟化油 (Fluorinated)		280	-35~+260	高、低温脂 high-low temperature grease	
	Barrierta EL	聚四氟乙烯 (PTFE)	氟化油 (Fluorinated)		280	-50~+180	高、低温脂 high-low temperature grease	
	Barrierta IMI/V	聚四氟乙烯 (PTFE)	氟化油 (Fluorinated)		280	-50~+220	高、低温脂 high-low temperature grease	
	Asonic HQ72-102	素尿 (Urea)	酯(Ester)	240	250~280	-40~+180	高、低温和低噪声脂 high-low temperature and low noise grease	
	Petamo GHY133	素尿 (Urea)	合成矿油 (Synthetic Mineral oil)	240	250~280	-25~+150	常温脂 normal temperature grease	
	BQH72-102	素脲 (Polyurea)	酯(Ester)	250		-40~+180	高温长寿命脂 high temperature longevity grease	
Dow Corning	Molykote 33M	锂基 (Lithium)	硅油 (Silicone)	210	260	-70~+180	高、低温脂 high-low temperature grease	LY81
	Molykote 44M	锂基 (Lithium)	硅油 (Silicone)	204	260	-40~+200	高温脂 high temperature grease	LY13
	Molykote 55M	锂基 (Lithium)	硅油 (Silicone)			-55~+165	低温脂 low-temperature grease	LY52
	Molykote BR2 plus	锂基 (Lithium)	矿物 (Mineral)		280	-30~+150	高速脂 high speed grease	
	Molykote FS1292	聚四氟乙烯 (PTFE)	硅 (Phlorosilicon)	≥232	310	-40~+200	高温脂 high temperature grease	LY59
	Molykote FS3451	聚四氟乙烯 (PTFE)	硅 (Phlorosilicon)	≥260	285	-40~+230	抗化学溶剂脂 anti-chemical solvent grease	

(注: *表示MOGB常用油脂) NOTE: *indicates the commonly-used grease of MOGB.

MOGB油脂一览表 MOGB GREASE DATA SHEET								
制造厂 Maker	牌号 Brand	增稠剂 Viscosity	基油 Base oil	滴点 Drop point °C	稠度 Consistency	使用 温度范围 Operating temperature range °C	选用原则 Selection criteria	NMB 代码 Code
Dow Corning	Molykote 41		硅油 (Silicone)		260	-20~+290	常温脂 normal temperature grease	
	Molykote BG20	锂基 (Lithium)	合成油 (Synthetic oil)	230	265~295	-50~+180	高温高速脂 high temperature high speed grease	
Shell	*Alvania RL2	锂基 (Lithium)	矿物 (Mineral)	182	272	-25~+120	常温脂 normal temperature grease	LY83
	Alvania No.3	锂基 (Lithium)	矿物 (Mineral)	183	233	-20~+135	常温脂 normal temperature grease	LY84
	Alvania RA	锂基 (Lithium)	矿物 (Mineral)	183	252	-25~+120	常温脂 normal temperature grease	LY18
	Alvania EP2	锂基 (Lithium)	矿物 (Mineral)	185	276	-10~+100	常温脂 normal temperature grease	
	Sunlight 2	锂基 (Lithium)	矿物 (Mineral)	196	273	-20~+120	常温脂 normal temperature grease	
	Dolium R		矿物 (Mineral)	238	281	-20~+140	常温脂 normal temperature grease	LY119
	Aero shell No.5	Microgel	矿物 (Mineral)	≥260	282	-10~+130	常温脂 normal temperature grease	LG35
	Aero shell No.7	Microgel	矿物 (Mineral)	≥260	288	-70~+150	低温脂 low-temperature grease	LG49
	Aero shell No.15A	聚四氟乙烯 (PTFE)	双酯 (Diester)	≥260	280	-70~+260	高、低温脂 high-low temperature grease	
	Alvania RLQ2	锂基 (Lithium)	矿物 (Mineral)	195	266	-50~+150	低噪声、高速脂 low noise high speed grease	
	Mobil Oil	Mobilux2	锂基 (Lithium)	矿物 (Mineral)		280	-20~+120	常温脂 normal temperature grease
Mobil 22		锂基 (Lithium)	双酯-矿物 (Diester Mineral)	192	274	-50~+140	低温脂 low-temperature grease	
*Mobil 28		膨润土 (Bentonite)	合成碳氢 (Synthetic hydrocarbon)	≥260	280	-60~+180	高、低温脂 high-low temperature grease	LY48
Mobilplex 47			矿物 (Mineral)	≥260	280	-20~+120	常温脂 normal temperature grease	

(注: *表示MOGB常用油脂) NOTE: *indicates the commonly-used grease of MOGB.

常用润滑脂的明细表
A DETAIL LIST OF THE COMMONLY-USED LUBRICATING GREASE

常用润滑脂的明细表
A DETAIL LIST OF THE COMMONLY-USED LUBRICATING GREASE

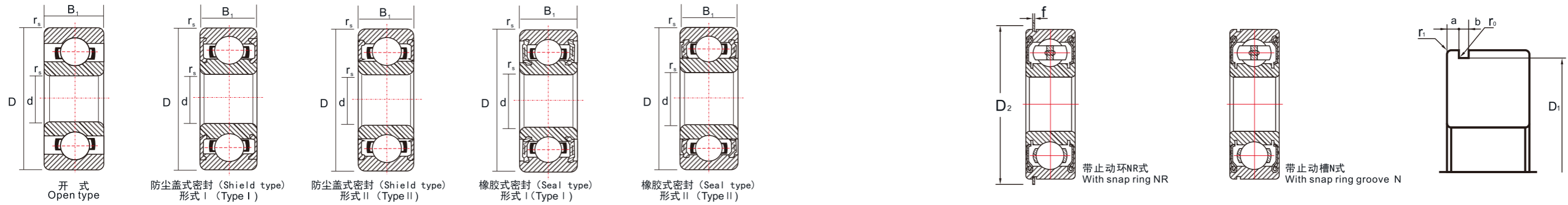
MOGB油脂一览表 MOGB GREASE DATA SHEET								
制造厂 Maker	牌号 Brand	增稠剂 Viscosity	基油 Base oil	滴点 Drop point °C	稠度 Consistency	使用 温度范围 Operating temperature range °C	选用原则 Selection criteria	NMB 代码 Code
Mobil Oil	Mobilith SHC100	锂基 (Lithium)	合成油 (Synthetic oil)	250	265~295	-40~+170	高速脂 high speed grease	
	Mobilith SHC220	锂基 (Lithium)	合成油 (Synthetic oil)	250	265~295	-40~+170	多用途脂 multiple use grease	
	Mobilitemp SHC22	粘土 (glue-earth)	合成油 (Synthetic oil)	250	265~295	-50~+180	高速、高温脂 high speed, high temperature grease	
	Mobilitemp SHC100	粘土 (glue-earth)	合成油 (Synthetic oil)	250	265~295	-50~+200	高速、高温脂 high speed, high temperature grease	
Du Pont	Krytox 240AC	聚四氟乙烯 (PTFE)	氟化油 (PFAE)		282	-34~+288	高温脂 high temperature grease (航空油脂av'grease)	
	Krytox 283AC	聚四氟乙烯 (PTFE)	氟化油 (PFAE)		229	-34~+288	高温脂 high temperature grease (航空油脂av'grease)	
	Krytox GPL205	聚四氟乙烯 (PTFE)	氟化油 (PFAE)			-36~+204	高温脂 high temperature grease	
	Krytox GPL223	聚四氟乙烯 (PTFE)	氟化油 (PFAE)			-60~+154	高温、发电机、风扇、 离合器轴承脂 high temperature, alternator, fan, clutch bearing grease	
	Krytox GPL224	聚四氟乙烯 (PTFE)	氟化油 (PFAE)			-51~+179		
	Krytox GPL225	聚四氟乙烯 (PTFE)	氟化油 (PFAE)			-36~+204	气泵轴承脂 air pump bearing grease	
	*Krytox GPL226	聚四氟乙烯 (PTFE)	氟化油 (PFAE)			-36~+260	Cv万向节 Cv joint	
Toray silicone	SH44M	锂基 (Lithium)	硅 (Phlorosilicon)	210	260	-40~+180	高温脂 high temperature grease	LY115
	SH33L	锂基 (Lithium)	硅 (Phlorosilicon)	210	300	-70~+140	低温脂 low temperature grease	
	SH41	锂基 (Lithium)	硅 (Phlorosilicon)		280	-10~+200	高温脂 high temperature grease	
Caltex	Chevron SRI-2	素尿 (Urea)	矿物 (Mineral)	243	280	-30~+150	高温脂 high temperature grease	LY75
	Polystar Synthetic 2#	素尿 (Urea)	矿物 (Mineral)	245	288	-30~+180	高温脂 high temperature grease	

(注: *表示MOGB常用油脂) NOTE: *indicates the commonly-used grease of MOGB.

MOGB油脂一览表 MOGB GREASE DATA SHEET								
制造厂 Maker	牌号 Brand	增稠剂 Viscosity	基油 Base oil	滴点 Drop point °C	稠度 Consistency	使用 温度范围 Operating temperature range °C	选用原则 Selection criteria	NMB 代码 Code
Caltex	RPM Greas SRI-2	素尿 (Polyurea)	矿物 (Mineral)	243	280	-30~+150	高温高速脂 high temperature high speed grease	
	RPM Greas SRI OEM	素尿 (Polyurea)	矿物 (Mineral)	243	280	-30~+150	低温高速脂 low temperature high speed grease	
	Starplex EP2	复合锂基 (Complex Lithium)	矿物 (Mineral)	290	280	-25~+130	极压脂EP grease	
General Electric	Anderol L-793A	锂基 (Lithium)	双酯 (Diester)			-60~+150	低温脂 low-temperature grease	
	Versilube G-300	锂基 (Lithium)	硅油 (Silicone)			-70~+230	高、低温 high-low temperature grease	LY15
	Versilube F-50		硅油 (Silicone)			-70~+230	高、低温 high-low temperature grease	LY5
Lubcon	Turmogrease N2	素尿 (Polyurea)	合成油 / 酯 (PAO/Ester)	≥250	280	-40~+160	通用轴承 commonly-used bearing	
	Lubteksonic BQg	锂基 (Lithium)	矿物 (Mineral)	250	280	-35~+150	低噪声 low noise	
	Turmogrease SHL182	锂基 (Lithium)	合成油 / 酯 (PAO/Ester)	250	280	-70~+130	低温高速脂 low temperature high speed grease	
	Turmogrease SHL252	特种锂基 (Lithium)	合成油 / 酯 (PAO/Ester)	220	280	-40~+120	高速脂high speed grease	
	Turmoplex TML15	锂基 (Lithium)	酯(Ester)	290	280	-35~+160 (180)	高温高速脂 high temperature high speed grease	
	Turmogrease CX112K	锂基 (Lithium)	矿物 / 合成油 (Mineral oil/ Synthetic)	190	265~295	-35~+140 (160)	低噪声 low noise	
	Turmogrease NBI300	素尿 (Polyurea)	合成油酯 (PAO/Ester)	250	280	-40~+180	高温高负荷脂 high temperature high load grease	
MSK	MSK-L2200H	锂皂	合成油 (Synthetic oil)	190	250	-40~+150	低噪声Low noise	
Fomblin	GRM30	聚四氟乙烯 (PTFE)				-60~+230	高、低温脂 high-low temperature grease	

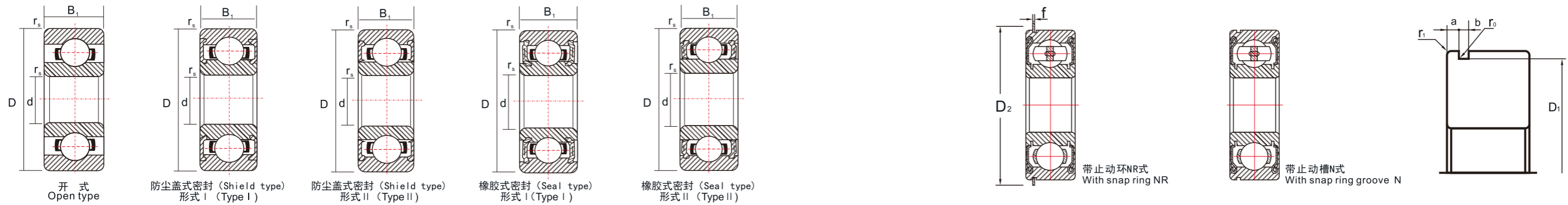
(注: *表示MOGB常用油脂) NOTE: *indicates the commonly-used grease of MOGB.

深沟球轴承/公制系列
DEEP GROOVE BALL BEARINGS METRIC SERIES



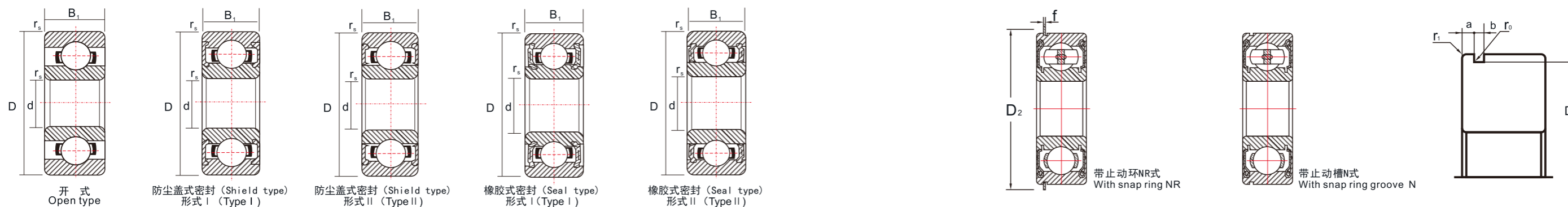
外形尺寸 Boundary dimensions (mm)				额定负荷 Load rating(N)		极限转速 Limiting speeds(rpm)			轴承型号 bearing numbers Deep groove ball bearings		轴承型号 bearing numbers Deep groove ball bearings				止动换槽尺寸 (mm) Snap ring groove dimensions					止动环尺寸 (mm) Snap ring dimensions		
d	D	B ₁	r _{smin}	C _r	C _{or}	Grease		Oil	MOGB		NSK		带止动环槽 With snap ring groove	带止动环 With snap ring	a Max.	b min.	D ₁ max.	r ₀ max.	r ₁ min.	D ₂ max.	f Max.	
						Non contact seal	Contact seal		open	close	open	close										
10	19	5	0.3	1600	755	34000	24000	40000	61800	61800-2Z-2RS-2RZ	6800	6800ZZVVDD	-	-	-	-	-	-	-	-	-	-
	19	7	0.3	1600	755	34000	24000	40000	63800	63800-2Z-2RS-2RZ	-	-	-	-	-	-	-	-	-	-	-	-
	22	6	0.3	2700	1270	32000	22000	38000	61900	61900-2Z-2RS-2RZ	6900	6900ZZVVDD	N	NR	1.05	0.8	20.8	0.2	0.2	24.8	0.7	
	26	8	0.3	4570	1970	30000	22000	36000	6000	6000-2Z-2RS-2RZ	6000	6000ZZVVDD	N	NR	1.73	0.8	25.15	0.2	0.3	29.2	0.7	
	26	10	0.3	4570	1970	30000	22000	36000	62000	62000-2Z-2RS-2RZ	-	-	-	-	-	-	-	-	-	-	-	-
	30	9	0.3	5100	2390	24000	18000	30000	6200	6200-2Z-2RS-2RZ	6200	6200ZZVVDD	N	NR	2.06	1.35	28.17	0.4	0.5	34.7	1.12	
	35	11	0.3	7650	3470	22000	17000	26000	6300	6300-2Z-2RS-2RZ	6300	6300ZZVVDD	N	NR	2.06	1.35	33.17	0.4	0.5	39.7	1.12	
12	21	5	0.3	1920	1040	32000	20000	38000	61801	61801-2Z-2RS-2RZ	6801	6801ZZVVDD	-	-	-	-	-	-	-	-	-	-
	24	6	0.3	2890	1460	30000	20000	36000	61901	61901-2Z-2RS-2RZ	6901	6901ZZVVDD	N	NR	1.05	0.8	22.8	0.2	0.2	26.8	0.7	
	28	7	0.3	5100	2390	28000	-	32000	16001	-	16001	-	-	-	-	-	-	-	-	-	-	-
	28	8	0.3	5100	2390	28000	18000	32000	6001	6001-2Z-2RS-2RZ	6001	6001ZZVVDD	N	NR	1.74	0.96	26.8	0.26	0.3	30.8	0.85	
	28	10	0.3	5100	2390	28000	18000	32000	62001	62001-2Z-2RS-2RZ	-	-	-	-	-	-	-	-	-	-	-	-
	28	12	0.3	5100	2390	28000	18000	32000	63001	63001-2Z-2RS-2RZ	-	-	-	-	-	-	-	-	-	-	-	-
	32	10	0.6	6800	3050	22000	17000	28000	6201	6201-2Z-2RS-2RZ	6201	6201ZZVVDD	N	NR	2.06	1.35	30.15	0.4	0.5	36.7	1.12	
	32	14	0.6	6820	3060	22000	17000	28000	62201	62201-2Z-2RS-2RZ	-	-	-	-	-	-	-	-	-	-	-	-
15	37	12	1.0	9700	4200	20000	16000	24000	6301	6301-2Z-2RS-2RZ	6301	6301ZZVVDD	N	NR	2.06	1.35	34.77	0.4	0.5	41.3	1.12	
	24	5	0.3	2070	1260	28000	17000	34000	61802	61802-2Z-2RS-2RZ	6802	6802ZZVVDD	-	-	-	-	-	-	-	-	-	-
	28	7	0.3	4300	2250	26000	17000	30000	61902	61902-2Z-2RS-2RZ	6902	6902ZZVVDD	N	NR	1.3	0.95	26.7	0.25	0.3	30.8	0.85	
	32	8	0.3	5600	2840	24000	-	28000	16002	-	16002	-	-	-	-	-	-	-	-	-	-	-
	32	9	0.3	5600	2840	24000	15000	28000	6002	6002-2Z-2RS-2RZ	6002	6002ZZVVDD	N	NR	2.06	1.35	30.15	0.4	0.3	36.7	1.12	
	32	11	0.3	5600	2840	24000	15000	28000	62002	62002-2Z-2RS-2RZ	-	-	-	-	-	-	-	-	-	-	-	-
	35	11	0.6	7630	3720	20000	14000	24000	6202	6202-2Z-2RS-2RZ	6202	6202ZZVVDD	N	NR	2.06	1.35	33.17	0.4	0.5	39.7	1.12	
	35	14	0.6	7630	3720	20000	14000	24000	62202	62202-2Z-2RS-2RZ	-	-	-	-	-	-	-	-	-	-	-	-
42	13	1	11400	5430	17000	13000	20000	6302	6302-2Z-2RS-2RZ	6302	6302ZZVVDD	N	NR	2.06	1.35	39.75	0.4	0.5	46.3	1.12		

深沟球轴承/公制系列
DEEP GROOVE BALL BEARINGS METRIC SERIES



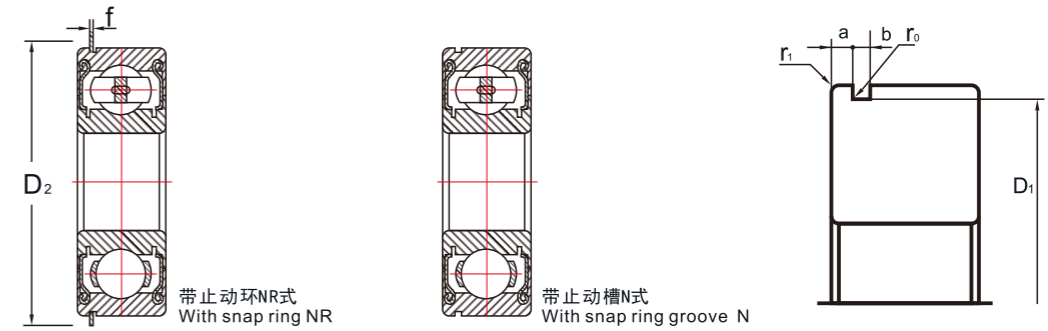
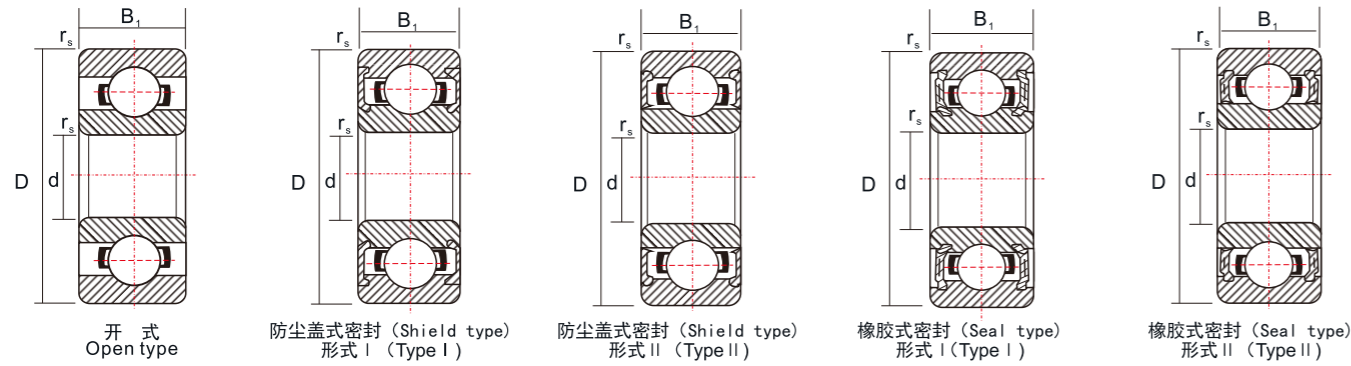
外形尺寸 Boundary dimensions (mm)				额定负荷 Load rating(N)		极限转速 Limiting speeds(rpm)			轴承型号 bearing numbers Deep groove ball bearings		轴承型号 bearing numbers Deep groove ball bearings				止动换槽尺寸 (mm) Snap ring groove dimensions					止动环尺寸 (mm) Snap ring dimensions	
						Grease		Oil	MOGB		NSK		带止动环槽 With snap ring groove	带止动环 With snap ring	a Max.	b min.	D ₁ max.	r ₀ max.	r ₁ min.	D ₂ max.	f Max.
d	D	B ₁	r _{smin}	C _r	C _{or}	Non contact seal	Contact seal		open	close	open	close									
17	26	5	0.3	2140	1370	26000	15000	30000	61803	61803 -2Z -2RS -2RZ	6803	6803ZZVVDD	-	-	-	-	-	-	-	-	
	30	7	0.3	4600	2550	24000	15000	28000	61903	61903 -2Z -2RS -2RZ	6903	6903ZZVVDD	N	NR	1.3	0.95	28.7	0.25	0.3	32.8	0.85
	35	8	0.3	6000	3250	22000	-	26000	16003	-	16003	-	-	-	-	-	-	-	-	-	-
	35	10	0.3	6000	3250	22000	13000	26000	6003	6003 -2Z -2RS -2RZ	6003	6003ZZVVDD	N	NR	2.06	1.35	33.17	0.4	0.3	39.7	1.12
	40	12	0.6	9550	4800	17000	12000	20000	6203	6203 -2Z -2RS -2RZ	6203	6203ZZVVDD	N	NR	2.06	1.35	38.10	0.4	0.5	44.6	1.12
	47	14	1.0	13580	6580	15000	11000	18000	6303	6303 -2Z -2RS -2RZ	6303	6303ZZVVDD	N	NR	2.46	1.35	44.60	0.4	0.5	52.7	1.12
20	27	4	0.2	1040	730	28000	-	34000	61704	61704 -2ZL	-	-	-	-	-	-	-	-	-	-	
	32	7	0.3	3480	2230	22000	13000	26000	61804	61804 -2Z -2RS -2RZ	6804	6804ZZVVDD	N	NR	1.3	0.95	30.7	0.25	0.3	34.8	0.85
	37	9	0.3	6370	3700	19000	12000	22000	61904	61904 -2Z -2RS -2RZ	6904	6904ZZVVDD	N	NR	1.7	0.95	35.7	0.25	0.3	39.8	0.85
	42	8	0.3	8400	4500	18000	-	20000	16004	-	16004	-	-	-	-	-	-	-	-	-	
	42	12	0.6	9400	5000	18000	11000	20000	6004	6004 -2Z -2RS -2RZ	6004	6004ZZVVDD	N	NR	2.06	1.35	39.75	0.4	0.5	46.3	1.12
	47	14	1.0	12800	6650	15000	11000	18000	6204	6204 -2Z -2RS -2RZ	6204	6204ZZVVDD	N	NR	2.46	1.35	44.60	0.4	0.5	52.7	1.12
	52	15	1.1	15900	7880	14000	10000	17000	6304	6304 -2Z -2RS -2RZ	6304	6304ZZVVDD	N	NR	2.46	1.35	49.73	0.4	0.5	57.9	1.12
	52	21	0.6	15900	7880	14000	10000	17000	62304	62304 -2Z -2RS -2RZ	-	-	-	-	-	-	-	-	-	-	
22	44	12	0.6	9400	5000	17000	11000	20000	60/20	60/20 -2Z -2RS -2RZ	60/20	60/22ZZVVDD	N	NR	2.06	1.35	41.75	0.4	0.5	48.3	1.12
	50	14	1.0	12900	6800	14000	9500	16000	62/22	62/22 -2Z -2RS -2RZ	62/22	62/22ZZVVDD	N	NR	2.46	1.35	47.60	0.4	0.5	55.7	1.12
	56	16	1.0	20700	10400	13000	9500	16000	63/22	63/22 -2Z -2RS -2RZ	63/22	63/22ZZVVDD	N	NR	2.46	1.35	53.60	0.4	0.5	61.7	1.12
25	32	7	0.2	1090	840	22000	13000	26000	64705	74705 -2ZL	-	-	N	NR	1.38	0.95	31.25	0.15	0.2	34.46	0.85
	37	7	0.3	3680	2630	18000	10000	22000	61805	61805 -2Z -2RS -2RZ	6805	6085ZZVVDD	N	NR	1.30	0.95	35.70	0.25	0.3	39.8	0.85
	42	9	0.3	7000	4550	16000	10000	19000	61905	61905 -2Z -2RS -2RZ	6905	6905ZZVVDD	N	NR	1.70	0.95	40.70	0.25	0.3	44.8	0.85
	47	8	0.3	10600	5850	15000	-	18000	16005	-	16005	-	-	-	-	-	-	-	-	-	
	47	12	0.6	10600	5850	15000	9500	18000	6005	6005 -2Z -2RS -2RZ	6005	6005ZZVVDD	N	-	2.06	1.35	44.60	0.4	0.5	52.7	1.12
	52	15	1.0	14000	7880	13000	9000	15000	6205	6205 -2Z -2RS -2RZ	6205	6205ZZVVDD	N	NR	2.46	1.35	49.73	0.4	0.5	57.9	1.12
	62	17	1.1	22400	11500	11000	8000	13000	6305	6305 -2Z -2RS -2RZ	6305	6305ZZVVDD	N	NR	3.28	1.9	59.61	0.6	0.5	67.7	1.7
28	52	12	0.6	12500	7400	14000	8500	16000	60/28	60/28 -2Z -2RS -2RZ	60/28	60/28ZZVVDD	N	NR	2.06	1.35	49.73	0.4	0.5	57.9	1.12
	58	16	1.0	17900	9760	12000	8000	14000	62/28	62/28 -2Z -2RS -2RZ	62/28	62/28ZZVVDD	N	NR	2.46	1.35	55.60	0.4	0.5	63.7	1.12
	68	18	1.1	25000	13880	10000	7500	13000	63/28	63/28 -2Z -2RS -2RZ	63/28	63/28ZZVVDD	N	NR	3.28	1.9	64.82	0.6	0.5	74.6	1.7

深沟球轴承/公制系列
DEEP GROOVE BALL BEARINGS METRIC SERIES



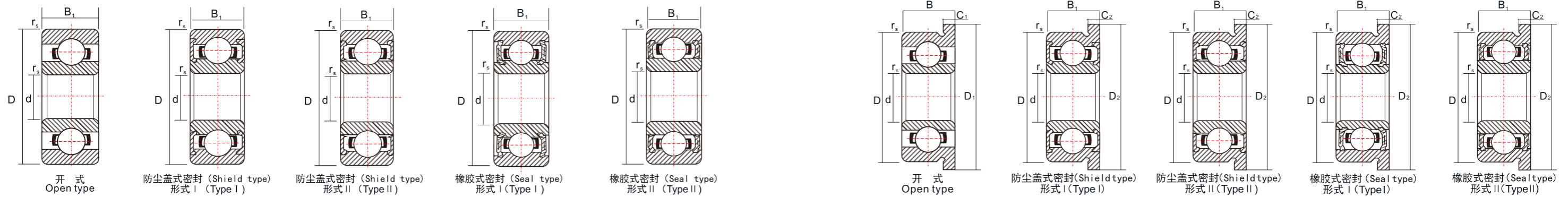
外形尺寸 Boundary dimensions (mm)			额定负荷 Load rating(N)			极限转速 Limiting speeds(rpm)			轴承型号 bearing numbers Deep groove ball bearings		轴承型号 bearing numbers Deep groove ball bearings				止动换槽尺寸 (mm) Snap ring groove dimensions					止动环尺寸 (mm) Snap ring dimensions	
d	D	B ₁	r _{smin}	C _r	C _{or}	Grease		Oil	MOGB		NSK		带止动环槽 With snap ring groove	带止动环 With snap ring	a Max.	b min.	D ₁ max.	r ₀ max.	r ₁ min.	D ₂ max.	f Max.
						Non contact seal	Contact seal		open	close	open	close									
30	37	7	0.2	1150	945	17000	10000	20000	64706	64706-2ZL	-	-	N	NR	1.38	0.95	36.15	0.15	0.2	39.2	0.85
	42	7	0.3	4500	3400	15000	9000	18000	61806	61806-2Z-2RS-2RZ	6806	6806ZZVDD	N	NR	1.30	0.95	40.70	0.25	0.3	44.8	0.85
	47	9	0.3	7250	5000	14000	8500	17000	61906	61906-2Z-2RS-2RZ	6906	6906ZZVDD	N	NR	1.70	0.95	45.70	0.25	0.3	49.8	0.85
	55	9	0.3	13200	8300	13000		15000	16006	-	16006	-	-	-	-	-	-	-	-	-	-
	55	13	1.0	13200	8300	13000	8000	15000	6006	6006-2Z-2RS-2RZ	6006	6006ZZVDD	N	NR	2.08	1.35	53.60	0.4	0.5	60.7	1.12
	62	16	1.0	19500	11300	11000	7500	13000	6206	6206-2Z-2RS-2RZ	6206	6206ZZVDD	N	NR	3.28	1.9	59.61	0.6	0.5	67.7	1.7
	72	19	1.1	26650	15000	9500	6700	12000	6306	6306-2Z-2RS-2RZ	6306	6306ZZVDD	N	NR	3.28	1.9	68.81	0.6	0.5	78.6	1.7
35	47	7	0.3	4750	38000	14000	7500	16000	61807	61807-2Z-2RS-2RZ	6807	6807ZZVDD	N	NR	1.30	0.95	45.70	0.25	0.3	49.8	0.85
	55	10	0.6	10400	7150	12000	7500	15000	61907	61907-2Z-2RS-2RZ	6907	6907ZZVDD	N	NR	1.7	0.95	53.7	0.25	0.5	57.8	0.85
	62	9	0.3	8200	6700	11000		13000	16007	-	16007	-	-	-	-	-	-	-	-	-	
	62	14	1.0	16000	10300	11000	6700	13000	6007	6007-2Z-2RS-2RZ	6007	6007ZZVDD	N	NR	2.08	1.9	59.61	0.6	0.5	67.7	1.7
	72	17	1.1	25700	15300	9500	6300	11000	6207	6207-2Z-2RS-2RZ	6207	6207ZZVDD	N	NR	3.28	1.9	68.81	0.6	0.5	78.9	1.7
	80	21	1.5	33600	19200	8500	6000	10000	6307	6307-2Z-2RS-2RZ	6307	6307ZZVDD	N	NR	3.28	1.9	76.81	0.6	0.5	86.6	1.7
40	52	7	0.3	4900	4170	12000	6700	14000	61808	61808-2Z-2RS-2RZ	6808	6808ZZVDD	N	NR	1.30	0.95	50.70	0.25	0.3	54.8	0.85
	62	12	0.6	13660	9940	11000	6300	13000	61908	61908-2Z-2RS-2RZ	6908	6908ZZVDD	N	NR	1.7	0.95	60.7	0.25	0.5	64.8	0.85
	68	9	0.3	8600	7500	10000		12000	16008	-	16008	-	-	-	-	-	-	-	-	-	
	68	15	1.0	16800	11500	10000	6000	12000	6008	6008-2Z-2RS-2RZ	6008	6008ZZVDD	N	NR	2.49	1.9	64.82	0.6	0.5	74.6	1.7
	80	18	1.1	29500	18100	8500	5600	10000	6208	6208-2Z-2RS-2RZ	6208	6208ZZVDD	N	NR	3.28	1.9	76.81	0.6	0.5	86.6	1.7
	90	23	1.5	40500	24000	7500	5300	9000	6308	6308-2Z-2RS-2RZ	6308	6308ZZVDD	N	NR	3.28	2.7	86.79	0.6	0.5	96.5	2.46
45	58	7	0.3	6380	5630	11000	6000	13000	61809	61809-2Z-2RS-2RZ	6809	6809ZZVDD	N	NR	1.30	0.95	56.70	0.25	0.3	60.8	0.85
	68	12	0.6	14100	10900	9500	5600	12000	61909	61909-2Z-2RS-2RZ	6909	6969ZZVDD	N	NR	1.7	0.95	66.7	0.25	0.5	70.8	0.85
	75	10	0.6	12900	10500	9000		11000	16009	-	16009	-	-	-	-	-	-	-	-	-	
	75	16	1.0	19900	14000	9000	5300	11000	6009	6009-2Z-2RS-2RZ	6009	6009ZZVDD	N	NR	2.49	1.9	71.83	0.6	0.5	81.6	1.7
	85	19	1.1	31600	20600	7500	5300	9000	6209	6209-2Z-2RS-2RZ	6209	6209ZZVDD	N	NR	3.28	1.9	81.81	0.6	0.5	91.6	1.7
	100	25	1.5	53000	32000	6700	4800	8000	6309	6309-2Z-2RS-2RZ	6309	6309ZZVDD	N	NR	3.28	2.7	96.80	0.6	0.5	106.5	2.46

深沟球轴承/公制系列
DEEP GROOVE BALL BEARINGS METRIC SERIES



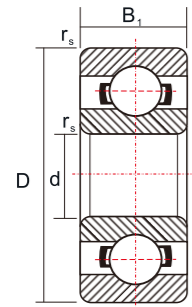
外形尺寸 Boundary dimensions (mm)				额定负荷 Load rating(N)		极限转速 Limiting speeds(rpm)			轴承型号 bearing numbers Deep groove ball bearings				轴承型号 bearing numbers Deep groove ball bearings				止动换槽尺寸 (mm) Snap ring groove dimensions					止动环尺寸 (mm) Snap ring dimensions		
d	D	B ₁	r _{smin}	C _r	C _{or}	Grease		Oil	MOGB				NSK		带止动环槽 With snap ring groove	带止动环 With snap ring	a Max.	b min.	D ₁ max.	r ₀ max.	r ₁ min.	D ₂ max.	f Max.	
						Non contact seal	Contact seal		open	close			open	close										
50	65	7	0.3	6580	6080	9500	5300	11000	61810	61810	-2Z	-2RS	-2RZ	6810	6810ZZVDD	N	NR	1.30	0.95	63.70	0.25	0.3	67.8	0.85
	72	12	0.6	14500	11700	9000	5300	11000	61910	61910	-2Z	-2RS	-2RZ	6910	6910ZZVDD	N	NR	1.70	0.95	70.70	0.25	0.5	74.8	0.85
	80	10	0.6	13700	11900	8500	—	10000	16010	—	—	—	—	—	—	—	—	—	—	—	—	—	—	
	80	16	1.0	20700	15400	8500	4800	10000	6010	6010	-2Z	-2RS	-2RZ	6010	6010ZZVDD	N	NR	2.49	1.9	76.81	0.6	0.5	86.6	1.7
	90	20	1.1	35000	23200	7100	4800	8500	6210	6210	-2Z	-2RS	-2RZ	6210	6210ZZVDD	N	NR	3.28	2.7	86.79	0.6	0.5	96.5	2.46
	110	27	2.0	61800	37800	6000	4300	7500	6310	6310	-2Z	-2RS	-2RZ	6310	6310ZZVDD	N	NR	3.28	2.7	106.81	0.6	0.5	116.6	2.46
55	72	9	0.3	8800	8080	8500	4800	10000	61811	61811	-2Z	-2RS	-2RZ	6811	6811ZZVDD	N	NR	1.70	0.95	70.70	0.25	0.3	74.8	0.85
	80	13	1.0	14800	12700	8000	4500	9500	61911	61911	-2Z	-2RS	-2RZ	6911	6911ZZVDD	N	NR	2.10	1.3	77.90	0.4	0.5	84.4	1.12
	90	11	0.6	15700	14200	7500	—	9000	16011	—	—	—	—	—	—	—	—	—	—	—	—	—	—	
	90	18	1.1	33100	23100	7500	4500	9000	6011	6011	-2Z	-2RS	-2RZ	6011	6011ZZVDD	N	NR	2.87	2.7	86.79	0.6	0.5	96.5	—
	100	21	1.5	43300	29300	6300	4300	7500	6211	6211	-2Z	-2RS	-2RZ	6211	6211ZZVDD	N	NR	3.28	2.7	96.80	0.6	0.5	106.5	1.7
	120	29	2.0	71500	44700	5600	4000	6700	6311	6311	-2Z	-2RS	-2RZ	6311	6311ZZVDD	N	NR	4.06	3.1	115.21	0.6	0.5	129.7	1.7
60	78	10	0.3	11500	10500	8000	4500	9600	61812	61812	-2Z	2RS	2RZ	6812	6812ZZVDD	N	NR	1.70	1.3	76.20	0.4	0.5	82.7	2.46
	85	13	1.0	19400	16300	7500	4300	9000	61912	61912	-2Z	2RS	2RZ	6912	6912ZZVDD	N	NR	2.10	1.3	82.90	0.4	0.3	89.4	0.85
	95	11	0.6	20000	17500	7100	—	8500	16012	—	—	—	—	—	—	—	—	—	—	—	—	—	—	
	95	18	1.1	29400	23200	7100	4000	8500	6012	6012	-2Z	2RS	2RZ	6012	6012ZZVDD	N	NR	2.87	2.7	91.82	0.6	0.5	101.6	2.46
	110	22	1.5	52500	36000	5600	3800	7100	6212	6212	-2Z	2RS	2RZ	6212	6212ZZVDD	N	NR	3.28	2.7	106.81	0.6	0.5	116.6	2.46
	130	31	2.1	82000	52000	5300	3600	6300	6312	6312	-2Z	2RS	2RZ	6312	6312ZZVDD	N	NR	4.06	3.1	125.22	0.6	0.5	139.7	2.82
65	85	10	0.6	11900	11500	7500	4000	8500	61813	61813	-2Z	2RS	2RZ	6813	6813ZZVDD	N	NR	1.70	1.3	82.90	0.4	0.5	89.4	1.12
	90	13	1.0	20000	17500	7100	4000	8500	61913	61913	-2Z	2RS	2RZ	6913	6913ZZVDD	N	NR	2.1	1.3	87.9	0.4	0.5	94.4	1.12
	100	11	0.6	20500	18600	6700	—	8000	16013	—	—	—	—	—	—	—	—	—	—	—	—	—	—	
	100	18	1.1	32000	25000	6700	4000	8000	6013	6013	-2Z	2RS	2RZ	6013	6013ZZVDD	N	NR	2.87	2.7	96.8	0.6	0.5	106.5	2.46
	120	23	1.5	57000	40000	5300	3600	6300	6213	6213	-2Z	2RS	2RZ	6213	6213ZZVDD	N	NR	4.06	3.1	115.21	0.6	0.5	129.7	2.82
	140	33	2.1	92500	60000	4800	3400	6000	6313	6313	-2Z	2RS	2RZ	6313	6313ZZVDD	N	NR	4.9	3.1	135.23	0.6	0.5	149.7	2.82
70	90	10	0.6	12100	11900	6700	3800	8000	61814	61814	-2Z	2RS	2RZ	6814	6814ZZVDD	N	NR	1.7	1.3	87.9	0.4	0.5	94.4	1.12
	100	16	1.0	23700	21200	6300	3600	7500	61914	61914	-2Z	2RS	2RZ	6914	6914ZZVDD	N	NR	2.5	1.3	97.9	0.4	0.5	104.4	1.12
	110	13	0.6	26800	23600	6000	—	7100	16014	—	—	—	—	—	—	—	—	—	—	—	—	—	—	
	110	20	1.1	38500	30500	6000	3600	7100	6014	6014	-2Z	2RS	2RZ	6014	6014ZZVDD	N	NR	2.87	2.7	106.81	0.6	0.5	116.6	2.46
	125	24	1.5	62000	44000	5000	3400	6300	6214	6214	-2Z	2RS	2RZ	6214	6214ZZVDD	N	NR	4.06	3.1	120.22	0.6	0.5	134.7	2.82
	150	35	2.1	10400	68000	4500	3200	5300	6314	6314	-2Z	2RS	2RZ	6314	6314ZZVDD	N	NR	4.9	3.1	145.24	0.6	0.5	159.7	2.82

深沟球轴承/英制系列
DEEP GROOVE BALL BEARINGS INCH SERIES

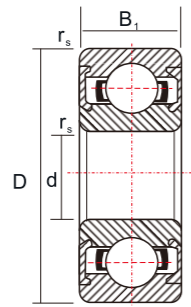


外形尺寸 Boundary dimensions (mm)										额定负荷 Load rating(N)	极限转速 Limiting speeds(rpm)		轴承型号 bearing number		轴承型号 bearing number						重量 Weight(g) weight refrence			
													Deep groove ball bearings		Deep groove ball bearings with flauged outer ring						Deep groove ball bearings		With flanged outer ring	
d	D	D ₁	B	B ₁	C ₁	C ₂	r _{smin}	C _r	C _{or}				MOGB		NSK	NSK	NSK	NSK	NSK	NSK	open	close	open	close
3.175	6.350	7.518	2.380	2.779	0.584	0.787	0.1	310	109	67000	80000	R144	R144 - 2Z	R144	R144 ZZS	FR144	FR144 - 2Z	FR144	FR144 ZZS	0.25	0.27	0.31	0.35	
	7.938	9.912	2.779	3.571	0.584	0.787	0.1	560	179	60000	67000	R2 - 5	R2 - 5 - 2Z	R2 - 5	R2 - 5 ZZ	FR2 - 5	FR2 - 5 - 2Z	FR2 - 5	FR2 - 5 ZZ	0.55	0.72	0.62	0.81	
	9.525	10.719	2.779	3.571	0.584	0.787	0.2	640	225	53000	63000	R2 - 6	R2 - 6 - 2Z	R2 - 6	R2 - 6 ZZ	R2 - 6	FR2 - 6 - 2Z	R2 - 6	FR2 - 6 ZZ	0.96	1.13	1.04	1.25	
	9.525	11.176	3.967	3.967	0.762	0.762	0.3	630	218	56000	67000	R2	R2 - 2Z	R2	R2 ZZ	FR2	FR2 - 2Z	FR2	FR2 ZZ	1.36	1.39	1.51	1.55	
	12.700	-	4.366	4.366	-	-	0.3	640	225	53000	63000	R2A	R2A - 2Z	R2A	R2A ZZ	-	-	-	-	3.30	3.23	-	-	
3.967	7.938	9.119	2.779	3.175	0.584	0.914	0.1	360	149	53000	63000	R155	R155 - 2Z	R155	R155 ZZS	FR155	FR155 - 2Z	FR155	FR155 ZZS	0.51	0.56	0.59	0.67	
4.762	7.938	9.119	2.779	3.175	0.584	0.914	0.1	360	149	53000	63000	R156	R156 - 2Z	R156	R156 ZZS	FR156	FR156 - 2Z	FR156	FR156 ZZS	0.39	0.42	0.47	0.53	
	9.525	10.719	3.175	3.175	0.584	0.787	0.1	710	270	50000	60000	R166	R166 - 2Z	R166	R166 ZZ	FR166	FR166 - 2Z	FR166	FR166 ZZ	0.81	0.85	0.90	0.98	
	12.700	14.351	3.967	4.978	1.067	1.067	0.3	1300	485	43000	53000	R3	R3 - 2Z	R3	R3 ZZ	R3	FR3 - 2Z	R3	FR3 ZZ	2.21	2.79	2.97	3.09	
	15.875	-	4.978	4.978	-	-	0.3	1480	615	38000	45000	R3A	R3A - 2Z	-	-	-	-	-	-	-	-	-	-	
6.350	9.525	10.719	3.175	3.175	0.584	0.914	0.1	375	173	48000	56000	R168	R168 - 2Z	FR168	R168 ZZS	FR168	FR168 - 2Z	FR168	FR168 ZZS	0.57	0.54	0.65	0.68	
	12.700	13.894	3.175	4.762	0.584	1.143	0.2	1080	440	40000	50000	R188	R188 - 2Z	FR188	R188 ZZ	FR188	FR188 - 2Z	FR188	FR188 ZZ	1.53	2.21	1.64	2.43	
	15.875	17.526	4.978	4.978	1.067	1.067	0.3	1470	600	38000	45000	R4	R4 - 2Z - 2LS - 2RZ	R4	R4 ZZ	FR4	FR4 - 2Z	FR4	FR4 ZZ	4.46	4.42	4.82	4.78	
	19.050	-	5.558	7.142	-	-	0.4	2220	895	36000	43000	R4A	R4A - 2Z - 2RS - 2LS - 2RZ	R4A	R4A ZZ	-	-	-	-	7.48	9.17	-	-	
7.938	12.700	13.894	3.967	3.967	0.787	0.787	0.2	540	276	40000	48000	R1810	R1810 - 2Z	R1810	R1810 ZZ	FR1810	FR1810 - 2Z	FR1810	FR1810 ZZ	1.56	1.48	1.71	1.63	
9.525	22.225	24.613	5.558	7.142	1.570	1.570	0.4	3300	1370	32000	38000	R6	R6 - 2Z - 2RS - 2LS - 2RZ	R6	R6 ZZ	FR6	FR6 - 2Z	FR6	FR6 ZZ	9.02	11.00	10.00	12.10	
12.700	28.757	31.120	6.350	7.938	1.575	1.575	0.4	5110	2380	26000	32000	R8	R8 - 2Z - 2LS	-	-	FR8	FR8 - 2Z	-	-	-	-	-	-	
15.875	34.925	-	7.142	8.733	-	-	0.8	6000	3250	22000	26000	R10	R10 - 2Z - 2LS	-	-	-	-	-	-	-	-	-	-	
19.050	41.275	-	7.938	11.113	-	-	0.8	7920	4490	17000	19000	R12	R12 - 2Z - 2LS	-	-	-	-	-	-	-	-	-	-	

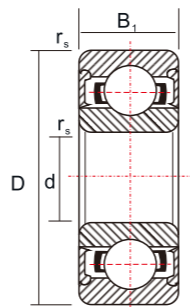
深沟球轴承 (摩托车)
DEEP GROOVE BALL BEARING (FOR MOTOR CYCLE)



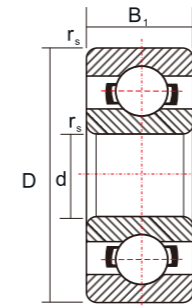
开式
Open type



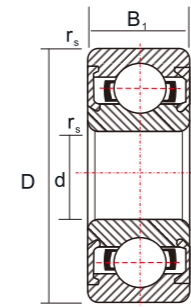
防尘盖式密封 (Shield type)
形式 I (Type I)



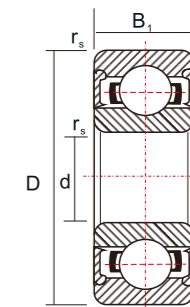
防尘盖式密封 (Shield type)
形式 II (Type II)



开式
Open type



防尘盖式密封 (Shield type)
形式 I (Type I)

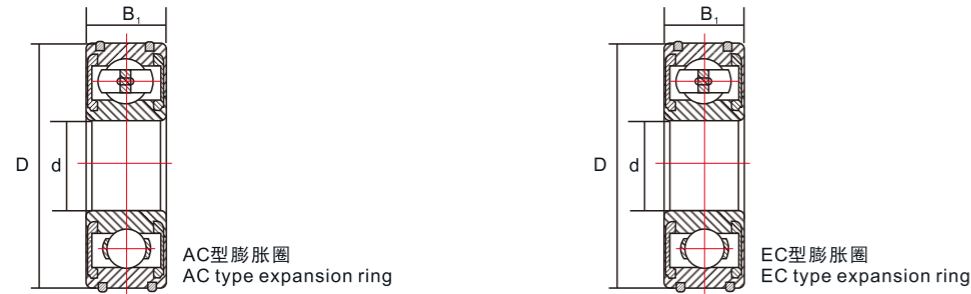


防尘盖式密封 (Shield type)
形式 II (Type II)

外形尺寸 Boundary dimensions (mm)				额定负荷 Load rating (N)		极限转速 Limiting speeds (rpm)			轴承型号 bearing numbers Deep groove ball bearings		适用机型 Applications
d	D	B ₁	r _{smin}	C _r	C _{or}	Grease		Oil	MOGB		
						Noncontact seal	Contact seal		Open	Closed	
8	28	9	0.3	4570	1970	28000	22000	34000	-	638-Z/P6	50
12	28	8	0.3	5100	2390	28000	18000	32000	6001	-	150
									6001/P6	-	157
									6001/P53Z2	-	160
	32	10	0.6	6800	3050	22000	17000	28000	6201	-	50,100
									6201/P6	-	50
									6201-P5	-	HN169M
37	12	1.0	9700	4200	20000	16000	24000	6301	-	153	
15	32	8	0.3	5600	2840	24000	15000	28000	16002/P6	-	凸轮轴 Convex axle
									6002	-	153
	35	11	0.6	7630	3720	20000	14000	24000	-	6002-RS/P5	157
									6202	-	153
									6202/P5	-	HN169M
									-	6202-RS/P6	247
42	13	1.0	11400	5430	17000	13000	20000	6302/P5	-	2V49	
17	35	8	0.3	6000	3250	22000	-	26000	16003	-	100
									16003/P6	-	100
									6003	-	50
									6003/P6	-	50
	40	12	0.6	9550	4800	17000	12000	20000	6003/P5	-	2V49
									-	6003-2RS/P6	50
									6203	-	-
42	13	0.6	9550	4800	17000	12000	20000	6203/P5	-	HN169M	
47	14	1.0	13580	6580	15000	11000	18000	-	6203X3/953Z2	141QMB 曲轴 (bent axle)	
20	42	12	0.6	9400	5000	18000	11000	20000	6004	-	-
									6004/P6	-	-
									6004/P53Z2	-	45QDC 曲轴 (bent axle)
									6004/P5	-	HN169, 2V49
									-	6004-2RS/P6	50
-	6004-2RS/P5	169									

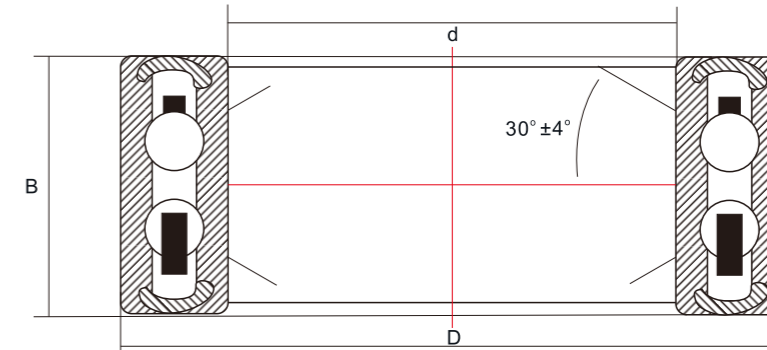
外形尺寸 Boundary dimensions (mm)				额定负荷 Load rating (N)		极限转速 Limiting speeds (rpm)			轴承型号 bearing numbers Deep groove ball bearings		适用机型 Applications
d	D	B ₁	r _{smin}	C _r	C _{or}	Grease		Oil	MOGB		
						Noncontact seal	Contact seal		Open	Closed	
20	47	14	1.0	12800	6650	15000	11000	18000	6204	-	100,125,150
									6204/P6	-	157
									6204/P5	-	169HV
									6204/P53	-	50
									6204/P53Z2	-	50
									-	6204-RS/P6	247
	52	12	1.1	10060	5850	14000	10000	17000	68304X2	-	-
	52	15	1.1	15900	7880	14000	10000	17000	6304	-	-
									6304/P6	-	-
									6304/P53Z2	-	150
6304D2X1									-	50	
22	47	14	1.0	12800	6650	15000	11000	18000	-	62/22X1-RS/P53Z2	253
									62/22/YA5	-	253
	50	14	1.0	12900	6800	14000	9500	16000	-	62/22YA5-2RS	253
									63/22X2JD2S1	-	153
									-	63/22X2-1-2RS	-
25	37	7	0.3	3680	2630	18000	10000	22000	61805	-	153
									6005/P5	-	2V49
	47	12	0.6	10060	5850	15000	9500	18000	6205/P5	-	153
									6205/P53Z2	-	AX100
	62	17	1.1	22400	11500	11000	8000	13000	6305/P5	-	-
									6305/P5Z2	-	247
62	16	1.1	22400	11500	11000	8000	13000	-	6305X2-Z/P53Z2	153-3 曲轴 (bent axle)	
28	58	16	1.0	17900	9760	12000	8000	14000	62/28	-	157
									63/28	-	157
									63/28YA5/P5	-	100
									-	63/28-RS	157
30	55	13	1.0	13200	8300	13000	8000	15000	-	63/28-RS/YA5P53Z2	157
									6006/P6	-	157
35	62	14	0.3	16000	10300	11000	6700	13000	6007/P63Z2	-	-
									6007/P53Z2	-	153-3 曲轴 (bent axle)

深沟球轴承 (EC, AC膨胀补偿型汽车发电机轴承)
DEEP GROOVE BALL BEARING (EC, AC EXPANSION COMPENSATION TYPE AUTOMOBILE GENERATOR BEARING)



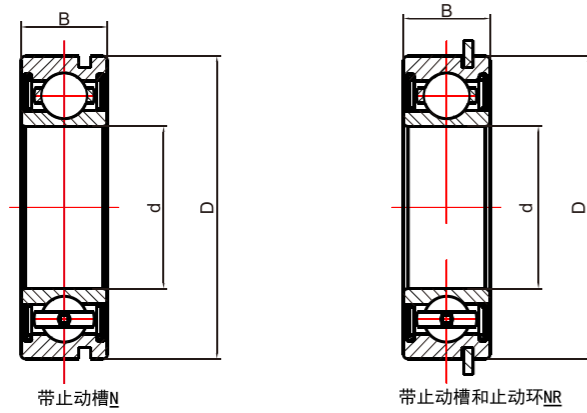
外形尺寸 Boundary dimensions (mm)				额定负荷 Load rating (N)		极限转速 Limiting speeds (rpm)			轴承型号 bearing numbers Deep groove ball bearings	
d	D	B ₁	r _{smin}	C _r	C _{or}	Grease		Oil	MOGB	
						Non contact seal	Contact seal		open	close
10	26	8	0.3	4570	1970	30000	22000	36000	EC -6000	EC -6000 -2Z-2RS -2RZ
	30	9	0.6	5100	2390	24000	18000	30000	AC -6000	AC -6000 -2Z-2RS -2RZ
	35	11	0.6	7650	3470	22000	17000	26000	EC -6200	EC -6200 -2Z-2RS -2RZ
12	28	8	0.3	5100	2390	28000	18000	32000	AC -6200	AC -6200 -2Z-2RS -2RZ
	32	10	0.6	6800	3050	22000	17000	28000	EC -6300	EC -6300 -2Z-2RS -2RZ
	37	12	1.0	9700	4200	20000	16000	24000	AC -6300	AC -6300 -2Z-2RS -2RZ
15	32	9	0.3	5600	1840	24000	15000	28000	EC -6001	EC -6001 -2Z-2RS -2RZ
	35	11	0.6	7630	3720	20000	14000	24000	AC -6001	AC -6001 -2Z-2RS -2RZ
	42	13	1.0	11400	5430	17000	13000	20000	EC -6201	EC -6201 -2Z-2RS -2RZ
17	40	12	0.6	9550	4800	17000	12000	20000	AC -6201	AC -6201 -2Z-2RS -2RZ
	47	14	1.0	13580	6580	15000	11000	18000	EC -6301	EC -6301 -2Z-2RS -2RZ
	52	15	1.0	15900	7880	14000	10000	17000	AC -6301	AC -6301 -2Z-2RS -2RZ
20	32	9	0.3	5600	1840	24000	15000	28000	EC -6002	EC -6002 -2Z-2RS -2RZ
	35	11	0.6	7630	3720	20000	14000	24000	AC -6002	AC -6002 -2Z-2RS -2RZ
	42	13	1.0	11400	5430	17000	13000	20000	EC -6202	EC -6202 -2Z-2RS -2RZ
25	40	12	0.6	9550	4800	17000	12000	20000	AC -6202	AC -6202 -2Z-2RS -2RZ
	47	14	1.0	13580	6580	15000	11000	18000	EC -6302	EC -6302 -2Z-2RS -2RZ
	52	15	1.0	15900	7880	14000	10000	17000	AC -6302	AC -6302 -2Z-2RS -2RZ
30	32	9	0.3	5600	1840	24000	15000	28000	EC -6003	EC -6003 -2Z-2RS -2RZ
	35	11	0.6	7630	3720	20000	14000	24000	AC -6003	AC -6003 -2Z-2RS -2RZ
	42	13	1.0	11400	5430	17000	13000	20000	EC -6203	EC -6203 -2Z-2RS -2RZ
35	40	12	0.6	9550	4800	17000	12000	20000	AC -6203	AC -6203 -2Z-2RS -2RZ
	47	14	1.0	13580	6580	15000	11000	18000	EC -6303	EC -6303 -2Z-2RS -2RZ
	52	15	1.0	15900	7880	14000	10000	17000	AC -6303	AC -6303 -2Z-2RS -2RZ
40	32	9	0.3	5600	1840	24000	15000	28000	EC -6004	EC -6004 -2Z-2RS -2RZ
	35	11	0.6	7630	3720	20000	14000	24000	AC -6004	AC -6004 -2Z-2RS -2RZ
	42	13	1.0	11400	5430	17000	13000	20000	EC -6204	EC -6204 -2Z-2RS -2RZ
45	40	12	0.6	9550	4800	17000	12000	20000	AC -6204	AC -6204 -2Z-2RS -2RZ
	47	14	1.0	13580	6580	15000	11000	18000	EC -6304	EC -6304 -2Z-2RS -2RZ
	52	15	1.0	15900	7880	14000	10000	17000	AC -6304	AC -6304 -2Z-2RS -2RZ
50	32	9	0.3	5600	1840	24000	15000	28000	EC -6005	EC -6005 -2Z-2RS -2RZ
	35	11	0.6	7630	3720	20000	14000	24000	AC -6005	AC -6005 -2Z-2RS -2RZ
	42	13	1.0	11400	5430	17000	13000	20000	EC -6205	EC -6205 -2Z-2RS -2RZ
55	40	12	0.6	9550	4800	17000	12000	20000	AC -6205	AC -6205 -2Z-2RS -2RZ
	47	14	1.0	13580	6580	15000	11000	18000	EC -6305	EC -6305 -2Z-2RS -2RZ
	52	15	1.0	15900	7880	14000	10000	17000	AC -6305	AC -6305 -2Z-2RS -2RZ
60	32	9	0.3	5600	1840	24000	15000	28000	EC -6006	EC -6006 -2Z-2RS -2RZ
	35	11	0.6	7630	3720	20000	14000	24000	AC -6006	AC -6006 -2Z-2RS -2RZ
	42	13	1.0	11400	5430	17000	13000	20000	EC -6206	EC -6206 -2Z-2RS -2RZ
65	40	12	0.6	9550	4800	17000	12000	20000	AC -6206	AC -6206 -2Z-2RS -2RZ
	47	14	1.0	13580	6580	15000	11000	18000	EC -6306	EC -6306 -2Z-2RS -2RZ
	52	15	1.0	15900	7880	14000	10000	17000	AC -6306	AC -6306 -2Z-2RS -2RZ

汽车空调压缩机电磁离合器轴承
ELECTROMAGNETIC CLUTCH BEARINGS FOR AUTOMOBILE AIR-CONDITION COMPRESSOR



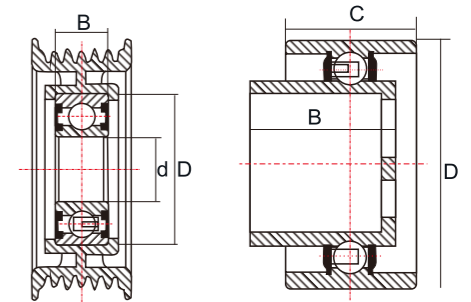
轴承代号 Bearing NO.	基本尺寸 Basic dimensions (mm)			基本额定动载荷 C _r	基本额定动载荷 C _{or}	极限转速 Limiting speeds (r/min)	质量 Mass	JB/T10531 -2005 轴承代号 Bearing NO.
	d	D	B			脂润滑 grease lubrication	参考 Ref	
30BD5222	30	52	22	17.38	13.47	7000	0.152	BD305222
30BD5223		52	23	16.30	13.26	7000	0.156	BD305223
30BD5523		55	23	16.30	13.26	7000	0.187	BD305523
3306 -2Z	32	72	30.2	37.23	26	3800	0.503	BD30723X2
32BD4718		47	18	10.69	9.2	7000	0.084	BD324718
32BD5523		55	23	16.30	13.26	6000	0.182	BD325523
35BD5020	35	50	20	10.66	9.46	8000	0.096	BD355020
35BD5220		52	20	10.82	9.86	7000	0.138	BD355220
35BD5222		52	22	10.82	9.86	7000	0.133	BD355222
35BD5520	40	55	20	15.54	13.28	6500	0.138	BD355520
10BD5724		57	24	14.22	13.28	6500	0.154	BD405724
40BD6220.625		62	20.625	17.58	15.93	6000	0.213	BD406221X2
40BD6224	45	62	24	17.58	15.93	6000	0.213	BD406224
40BD6830		68	30	20.91	18.55	4800	0.381	BD406830
45BD7532		75	32	22.14	24.2	4000	0.453	BD45732
33098	50	100	39.7	71.44	53.26	3600	1.288	-
3210B -2RS		90	30.2	43.89	37.73	3600	0.716	BD509030X2
3210BX2 -2RS		90	40	43.89	37.73	3600	0.986	BD509040

汽车变速箱轴承
AUTOMOBILE GEARBOX BEARINGS



型号 Bearing NO.	主要尺寸 Main dimensions (mm)			额定负荷 Load rating (kN)		极限转速 Limiting speeds(r/min)		质量 Mass (kg)
	d	D	B	C _r	C _{or}	脂润滑grease lubrication	油润滑oil lubrication	
66/23	23	56	15	18.40	9.3	14000	16000	0.151
60/28N	28	52	12	12.50	7.4	14000	16000	0.096
6204N	20	47	14	12.79	6.58	15000	18000	0.104
6205N	25	52	15	14.00	7.85	13000	15000	0.129
6907X2/25	25	55	10	9.51	6.87	14000	160000	0.116
609/28X3	28	47	8	7.28	4.96	14000	160000	0.051
BH66/20	20	62	16	19.46	11.31	11000	130000	0.252
6206N -2RS	30	62	16	19.50	11.3	11000	130000	0.199
62/22 -RS	22	50	14	12.90	6.8	14000	160000	0.119
62/26	26	52	15	14.02	7.88	13000	150000	0.125
6207N	35	72	17	25.70	15.3	9500	11000	0.284
62/28 -RS	28	58	16	26.70	14	10000	13000	0.287
60/28N -2RS	28	58	16	26.70	14	10000	13000	0.287
62/28/20A1	20	58	16	20.40	11.07	11000	13000	0.208
6304N	20	52	15	15.90	7.9	14000	17000	0.145
SC6304 -2RS	20	52	15	15.90	7.9	14000	17000	0.145
63/22	22	56	16	18.40	9.25	13000	16000	0.179
6305NX7	25	62	17	22.41	11.51	11000	13000	0.227
6305X3 -2RS	25	58	16	17.83	9.59	11000	13000	0.183
6305X3	25	58	16	26.62	13.88	11000	13000	0.301
6305N -2RS	25	62	17	20.60	11.2	11000	13000	0.235
63/28N	28	68	18	26.70	14	11000	13000	0.287
63/28N -2RS	28	68	18	26.70	14	10000	13000	0.287
6306N	30	72	19	26.70	15	10000	12000	0.345
6306N -2RS	30	72	19	26.70	15	9500	12000	0.345
6306X3N -2RS	30	75	21	32.85	17.51	9500	11000	0.436
63/32	32	75	21	29.90	17	9000	11000	0.389
63/32N -2RS	32	75	20	29.90	17	9000	11000	0.389
63/32X3NR -2RS	32	80	23	39.54	21.5	9000	10000	0.536
6307N	35	80	21	33.50	19.2	8500	10000	0.464
6307NY	35	80	21	33.50	19.2	8500	10000	0.464
6307X1N	35	90	21	37.04	21.72	7500	9000	0.662
6307X2N -2RS	35	80	24	39.54	21.5	8500	10000	0.513
6308NR -2RS	40	90	23	40.50	24	7500	9000	0.636
6309N	45	100	25	53.00	32	6700	8000	0.829
SC -1802117	45	85	30.2	51.89	39.97	7500	9000	0.829

汽车发动机紧张轮轴承
AUTOMOBILE TENSIONER BEARINGS



参考表1/Table1

参考表2/Table2

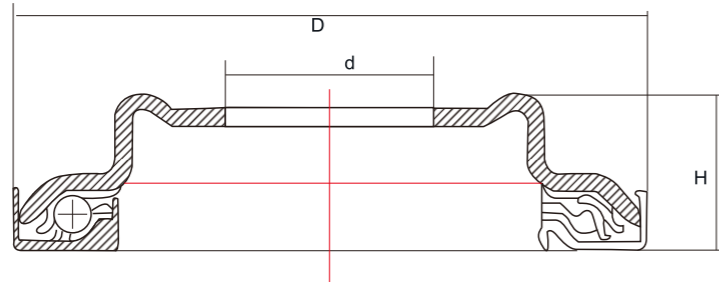
表1/Table1

轴承型号 Bearing No	基本尺寸 Basic Dimensions			基本额定载荷 Basic Load Rating		极限转速 Limiting Speed
	d	D	B	Cr	Cor	脂润滑 Grease Lubrication
	mm			KN		rpm
6001-2RS	12	28	8	5.11	2.39	28000
6005-2RS	25	47	12	10.06	5.85	15000
6006-2RS	30	55	13	12.23	8.30	13000
6007-2RS	35	62	14	16.00	10.30	11000
6203-2RS	17	40	12	9.57	4.79	17000
6203x2-2RS	17	40	14	9.57	4.79	17000
62/12.2-2RS	12.2	40	12	9.57	4.79	17000
62/28-2RS	28	55	16	17.90	9.77	12000
5203x2-2RS	17	40	20	13.30	8.69	12000
5005-2RS	25	47	24	16.35	11.70	15000
308D40	30	55	23	19.92	15.45	12000
358D5520	35	55	20	15.54	13.28	12000

表2/Table2

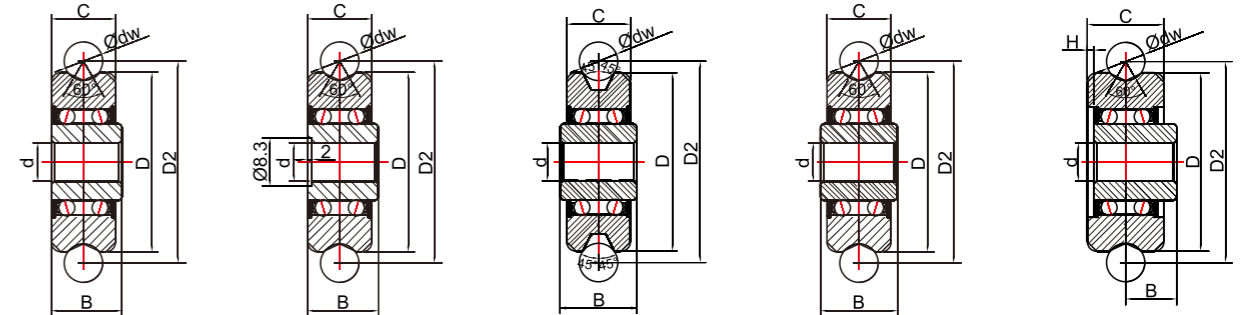
轴承代号 Bearing NO.	基本尺寸 Basic dimensions (mm)			基本额定载荷 Basic load rating (kN)		极限转速 Limiting speeds(rpm)	轴承代号 Bearing NO.	基本尺寸 Basic dimensions (mm)			基本额定载荷 Basic load rating (kN)		极限转速 Limiting speeds(rpm)
	D	C	B	C _r	C _{or}	脂润滑 grease lubrication		D	C	B	C _r	C _{or}	脂润滑 grease lubrication
FB0001	62	30	51	12.23	9.3	12000	FB0024	48	26	40	15.14	11.03	14000
FB0002	65	30.8	35.7	24.04	19.14	12000	FB0025	48	26	40	14.14	11.03	14000
FB0003	45	23	29.9	12.60	9.43	14000	FB0026	56.6	26	39	13.23	8.3	13000
FB0004	60	30	33.9	13.23	8.3	12000	FB0027	47	17	55	10.06	5.84	14000
FB0005	65	30.7	40	20.76	17.27	12000	FB0028	68	15	37	18.95	12.47	12000
FB0006	63.75	34	20.6	17.58	15.93	12000	FB0029	30	25	34.5	9.86	5.42	15000
FB0007	60	30.8	34	19.87	13.6	13000	FB0030	30	25	41.4	9.86	5.42	15000
FB0008	65	36.1	48.6	24.04	19.14	12000	FB0031	62	22	29.5	21.30	18.76	12000
FB0009	51	28	22.7	9.39	2.08	13000	FB0032	37	24	44.4	15.02	8.79	15000
FB0010	50	22	15	10.07	8.82	13000	FB0033	61	33	47.5	13.23	8.3	12000
FB0011	55	22	15	10.06	5.84	13000	FB0034	62	22	29.5	21.30	18.76	12000
FB0012	67	34	20.6	17.58	15.93	12000	FB0035	57	33	34	12.23	8.3	13000
FB0013	52	25	25.8	10.06	5.85	13000	FB0036	37	27	38.8	14.62	8.36	14000
FB0014	57	24	13	13.23	8.3	13000	FB0037	42	12	23.4	9.40	5.05	14000
FB0015	60	35	18	12.23	8.3	12000	FB0038	62	28.5	14	13.23	8.3	12000
FB0016	62	35	25.5	12.16	8.9	12000	FB0039	42	12	29.4	9.40	5.05	14000
FB0017	57.5	29	15	12.17	12.65	13000	FB0040	50	23	29.2	13.58	12.86	13000
FB0018	62	40.5	32	29.56	21.15	12000	FB0041	61	30	45.6	11.90	7.48	12000
FB0019	60	32	33	15.04	9.1	12000	FB0042	48	20	35	16.82	13.32	14000
FB0021	47	17	20.1	10.06	5.84	14000	FB0043	55	25	25.5	15.54	13.62	13000
FB0022	56	29	36.6	11.17	7.14	13000	FB0044	53	27	25.7	15.20	10.89	13000
FB0023	62	22	45.5	21.90	18.2	12000	FB0045	40	24	26	15.02	8.79	14000
							FB0046	55	19	20	11.60	6.41	13000

汽车减震器轴承
AUTOMOBILE SHOCK ABSORBER BEARINGS



外形尺寸 Boundary dimensions (mm)			基本额定负荷 Basic Load rating (kN)		质量 Mass (kg)	轴承代号 Bearing NO.
d	D	H	C _a	C _{oa}	参考 Ref	
12.0	45.5	19.0	19.7	37.2	0.071	JZ1246
14.3	45.0	14.0	19.8	37.2	0.061	JZ1445
33.0	98.0	38.0	13.8	41.6	0.291	JZ3398
33.2	114.5	33.6	13.1	44.7	0.217	JZ33115
35.0	113.0	61.0	13.0	42.0	0.229	JZ35113
35.5	69.5	9.0	20.0	47.2	0.116	JZ3670
35.5	107.0	44.0	13.2	41.9	0.190	JZ36107
38.0	66.0	14.5	15.8	46.1	0.075	JZ3866
38.5	151.0	50.0	29.7	78.6	0.371	JZ39151
50.0	78.0	17.8	17.4	58.6	0.070	JZ5078
50.5	77.0	14.8	17.2	57.2	0.088	JZ5177
58.5	98.0	16.7	15.0	50.2	0.092	JZ5998
59.0	87.0	12.0	13.9	44.7	0.092	JZ5987
61.0	112.0	30.0	13.2	41.8	0.147	JZ61112
61.8	88.5	12.5	18.4	68.4	0.070	JZ6289
65.7	99.8	20.0	18.9	44.3	0.127	JZ66100
66.0	90.0	10.0	27.4	77.6	0.156	JZ6690
68.3	112.0	25.0	19.5	79.6	0.281	JZ68112
71.5	115.0	33.3	13.2	41.9	0.221	JZ72115
75.0	126.5	53.5	14.8	55.8	0.243	JZ75127
78.5	128.0	45.8	14.7	55.8	0.216	JZ79128
79.0	126.0	29.5	15.3	58.6	0.145	JZ79126
79.8	104.5	15.0	19.9	83.8	0.114	JZ80105
80.5	117.6	14.2	16.7	67.0	0.083	JZ81118
82.6	137.0	50.3	20.9	96.3	0.276	JZ83137
86.0	117.8	11.8	16.7	67.0	0.079	JZ86118
87.0	196.5	61.0	20.4	90.8	0.470	JZ87197
90.0	122.0	17.0	20.9	96.3	0.153	JZ90122
91.5	111.0	16.0	20.4	90.7	0.110	JZ92111
99.5	140.0	34.0	15.1	64.2	0.360	JZ100140

SG导轨滚轮轴承
SG GUIDE ROLLER BEARING



参考表1/Table1 参考表1/Table1 参考表2/Table2 参考表2/Table2 参考表3/Table3

表1/Table1 非标导轨滚轮轴承 NON-STANDARD GUIDE ROLLER BEARING

型号/N0	d	D	C	B	D2	dw	Cw	Cow
SG66	6	22	10	11	25.52	6	3.45	1.75
SG66/8	8	22	10	14	25.52	6	3.45	1.75
SG25B-8	8	25	14	19	30	8	5.18	2.7
SG25B-10	8	25	14	19	32	10	5.18	2.7

表2/Table2 非标导轨滚轮轴承 NON-STANDARD GUIDE ROLLER BEARING

型号/N0	d	D	C	B	D2	dw	Cw	Cow
SG22	8	22.5	13.5	14.5	29.6	12	3.48	1.75
U16.5	5	16.5	9	11	21.51	8	1.27	0.82
U22	8	22.5	13.5	14.5	29.7	12	3.48	1.75

表3/Table3 SG导轨滚轮轴承 SG GUIDE ROLLER BEARING

型号/N0	d	D	C	B	D2	H	dw	Cw	Cow	重量g
SG10	4	13	6	3.52	16.08	0.8	5	1.05	0.85	7
SG15	5	17	8	5.75	20.46	1	6	1.27	0.82	8
SG15-10	5	17	8	5.75	25.5	1	10	1.27	0.82	9
SG20	6	24	11	7.25	28.62	1.2	8	3.4	1.7	25
SG25	8	30	14	8.5	35.77	1.5	10	3.67	2.28	49
SG25	12	42	19	12.5	48.93	1.5	12	8.5	5.1	136

