



# 宁波锐驰科技有限公司

NINGBO RIECHE TECHNOLOGY CO.,LTD.

工厂地址：浙江省余姚市朗霞街道朝阳路218号  
邮编 (P.c) : 315480

Add: NO. 218, Chaoyang Road, Langxia  
Street, Yuyao, Zhejiang Province

电话 ( Tel ) : 86-574-63886175

传真 ( Fax ) : 86-574-63886998

手机 ( M.T ) : 86-13906745683

邮箱 ( E-mail ) : danielhua@mogb-bearing.com

# RIECHE

SLIDING HARDWARE

[www.rieche.com.cn](http://www.rieche.com.cn)





**RIECHE**  
SLIDING WINDOW&DOOR



## 锐驰滑轮 RIECHE SLIDING

- 01 议程/AGENDA
- 03 制造基地/MANUFACTURING BASE
- 05 全自动自控设备/FULL-AUTOMATIC QUALITY CONTROL EQUIPMENTS
- 07 全自动生产线/FULL-AUTOMATIC BEARING PRODUCTION LINE
- 09 检测/INSPECTION SYSTEM
- 11 质量认证/CERTIFICATE OF CONFORMITY OF QUALITY MANAGEMENT SYSTEM CERTIFICATION
- 13 塑料滑轮（非磨加工）/plastic pulley(un ground)
- 14 塑料滑轮（磨加工）/plastic pulley(ground)
- 23 不锈钢滑轮（磨加工）/stainless steel pulley(ground)
- 24 非标轴承（车削轴承）/special bearing(turning)
- 26 满球轴承/full ball bearing
- 27 非标轴承（磨加工）/special bearing(ground)
- 30 滑轮组/sliding roller&trolley
- 32 冲压轴承/stamping bearing
- 35 万向球/ball transfer unit
- 36 脚轮轴承/castor wheel bearing
- 38 车库门轴承/garage door bearing
- 39 聚氨酯滑轮/urethane pulley
- 40 移门滑轮/sliding pulley
- 41 电梯轴承/elevator pulley
- 45 外球面轴承/spherical bearing
- 46 阻尼器/damper

## 制造基地/MANUFACTURING BASE

锐驰滑轮，2013年斥资1.6亿在浙江省余姚市兴建一座大型现代化制造基地，基地占地约31000平方米，建筑面积40000平方米，分设轴承和家具门窗滑轮两大厂区，拥有在国内机械制造领域先进的技术和管理团队，是目前国内屈指可数的集现代化科学管理和专业级轴承与家具门窗滑轮制造为一体的民营企业集团。

RIECHE SLIDING Spent \$26 milion to build a large modern manufacturing base in Yuyao City,Zhejiang Province in 2013.The base covers about 31000 square meters,the construction area is 40000 square meters.Which is divided into bearing and furniture&window roller factories.With the advanced technology and efficient managemen team in domestic machinery manufacturing field,our company can be counted as one of the best private enterprise which combines modern scientific managementand professional manufacturing together.



先进的生产设备是制造完美优质产品的关键，公司在规范自身生产规模和流程的同时不断与国际接轨，引进具有国际先进水平的生产设备，逐步实现生产智能化，规模化，操作规范化，使产品在工艺、质量、性能等每个环节都得到严格的控制，为国际大市场提供大规模高品质的产品。

The advanced production equipment is the key of producing high quality products, RIECHE keeps following the latest development of the technology, at the meantime, RIECHE insists a high standard of products, and makes the process of producing inteligentized and normalized. Thanks to the introduction of the most advanced equipment, we are able to apply high quality products to oversea markets.

## 全自动质控设备/ FULL-AUTOMATION QUALITY CONTROL EQUIPMENTS





锐驰滑轮，拥有目前最先进的全自动轴承生产线，注塑机，自动车床，铆接机，氩弧焊等专业生产设备。为满足客户对清洁度要求，公司车间采用全封闭设计，车间内空气全部经过5级过滤系统组成的送风装置送入。

RIECHE owns the most advanced automatic connection bearing production, plastic injection, CNC control turning machine, riveting machine, argon-arc welding etc. the workshop of RIECHE is totally closed from the outside environment, running 5-stages air filtering system 24hours a day to ensure the cleanness request from customer.

全自动生产线/FULL-AUTOMATIC BEARING PRODUCTION LINE



### 先进的检测系统/THE ADVANCED INSPECTION SYSTEM

锐驰不仅引进国际先进设备，还把一整套完整的检测系统引入到各个产品的研发，取材，生产，包装出库等整个生产流程中，以确保每个产品的高质量。

RIECHE not only imports international advanced testing equipment, but also leads a completed detection system into the whole production process of all kinds of products, including research and development/material/manufacture/packing/shipment and so on, to ensure the high quality of each product.

质量管理体系认证证书/CERTIFICATE OF CONFORMITY OF QUALITY MANAGEMENT SYSTEM CERTIFICATION

锐驰科技,主要生产微型轴承,家具建筑滑轮和五金件,锐驰与国内外众多著名企业结成战略合作关系,产品畅销国内外,成功进入欧美高端市场,在客户和消费者中有良好的声誉。

RIECHE, primarily produces miniature & small ball bearing, furniture & construction roller, hardware series. We have strategic partners all over the world, and our products sell well in domestic and enter in to top market of Europe and America, which wins a high reputation for our company.



# M1 塑料滑轮 (非磨加工)

plastic pulley(un-ground)

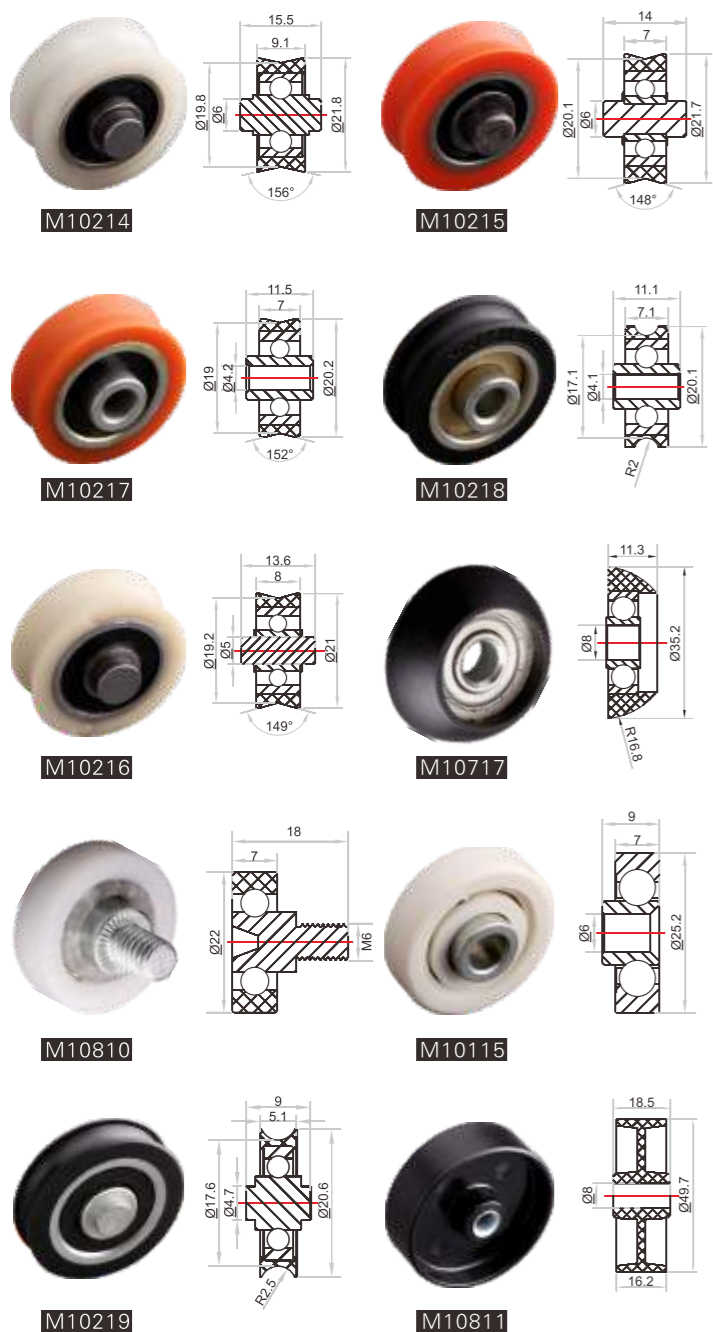

RIEHE  
SLIDING HARDWARE

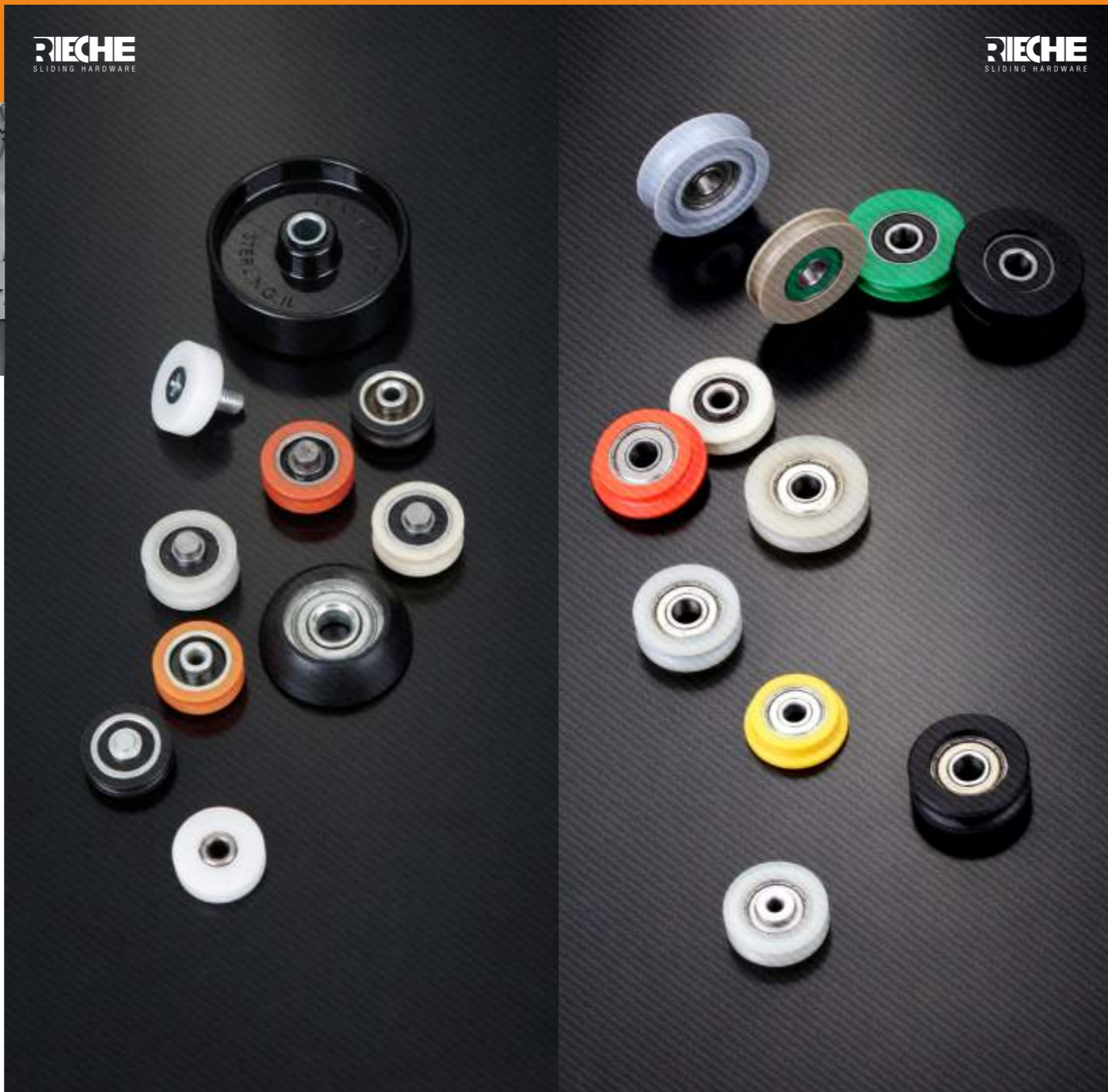

RIEHE  
SLIDING HARDWARE

# M2 塑料滑轮 (磨加工)

plastic pulley(ground)

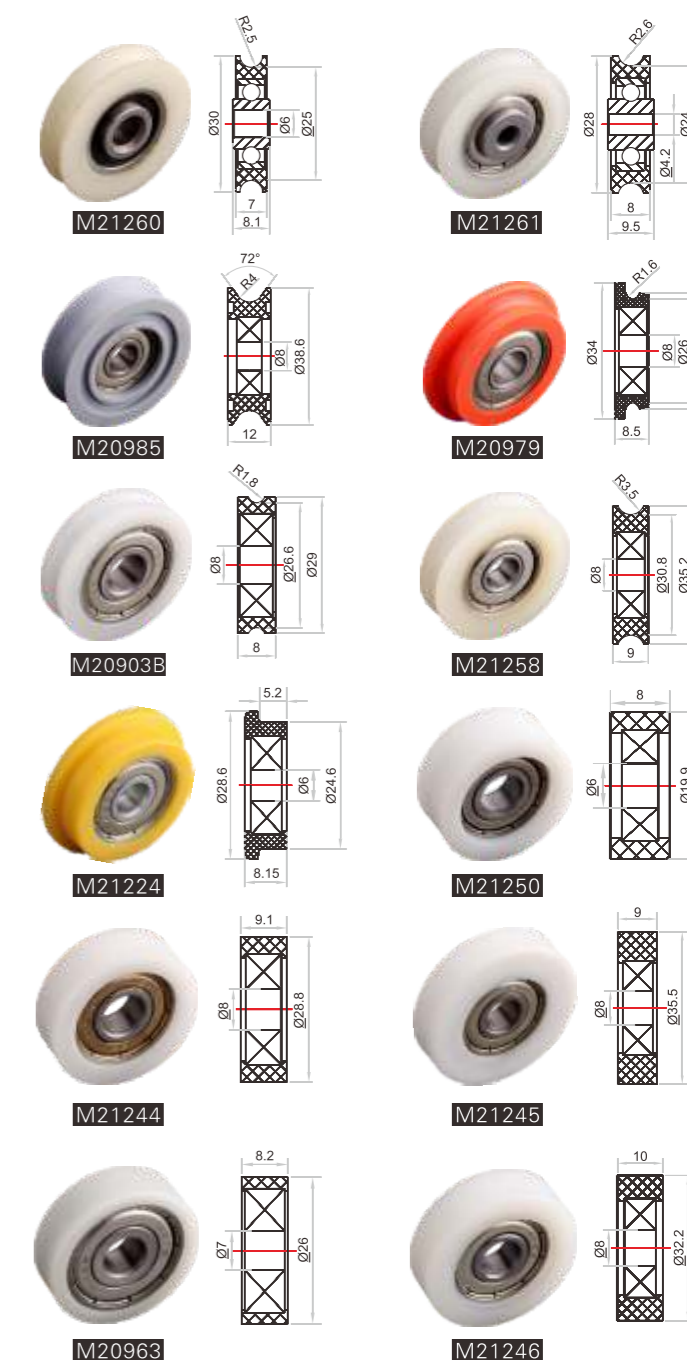

## 材质/Material

聚甲醛, 尼龙6, 尼龙66, 钢  
POM, PA6, PA66, Steel

## 运用领域/Application

门窗五金  
Door and Window Hardware

## 材质/Material

聚甲醛, 尼龙6, 尼龙66, 轴承钢  
POM, PA6, PA66, 100Cr6

## 运用领域/Application

门窗五金, 移门五金  
Door and Window Hardware  
Sliding System



# M2 塑料滑轮 (磨加工) plastic pulley(ground)



RIECHE  
SLIDING HARDWARE



RIECHE  
SLIDING HARDWARE

# M2 塑料滑轮 (磨加工) plastic pulley(ground)

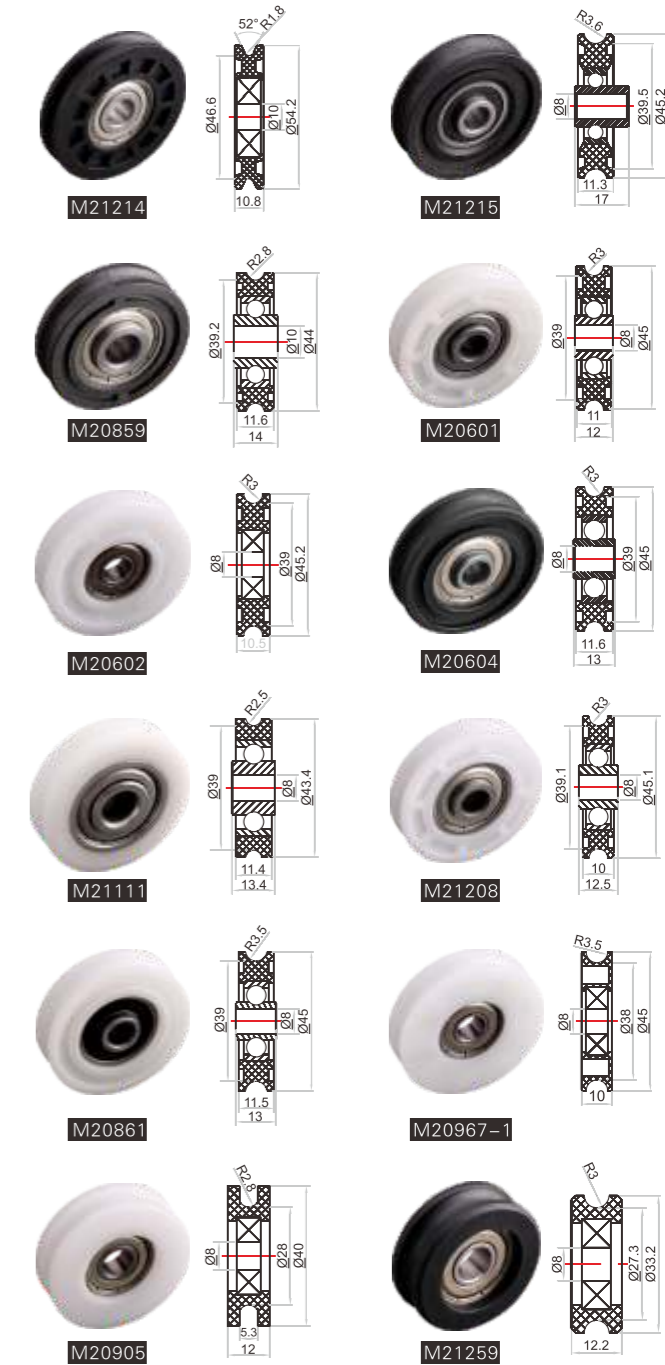
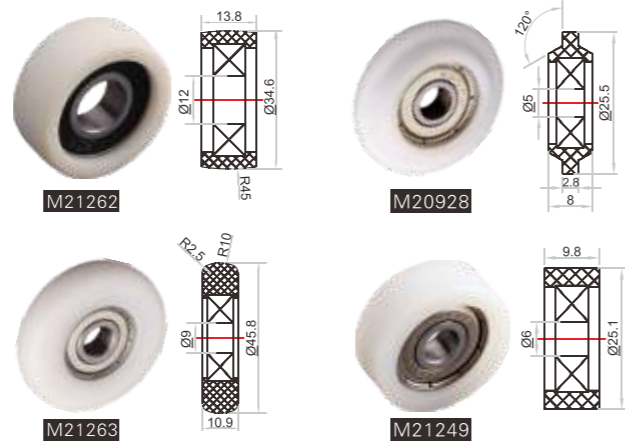
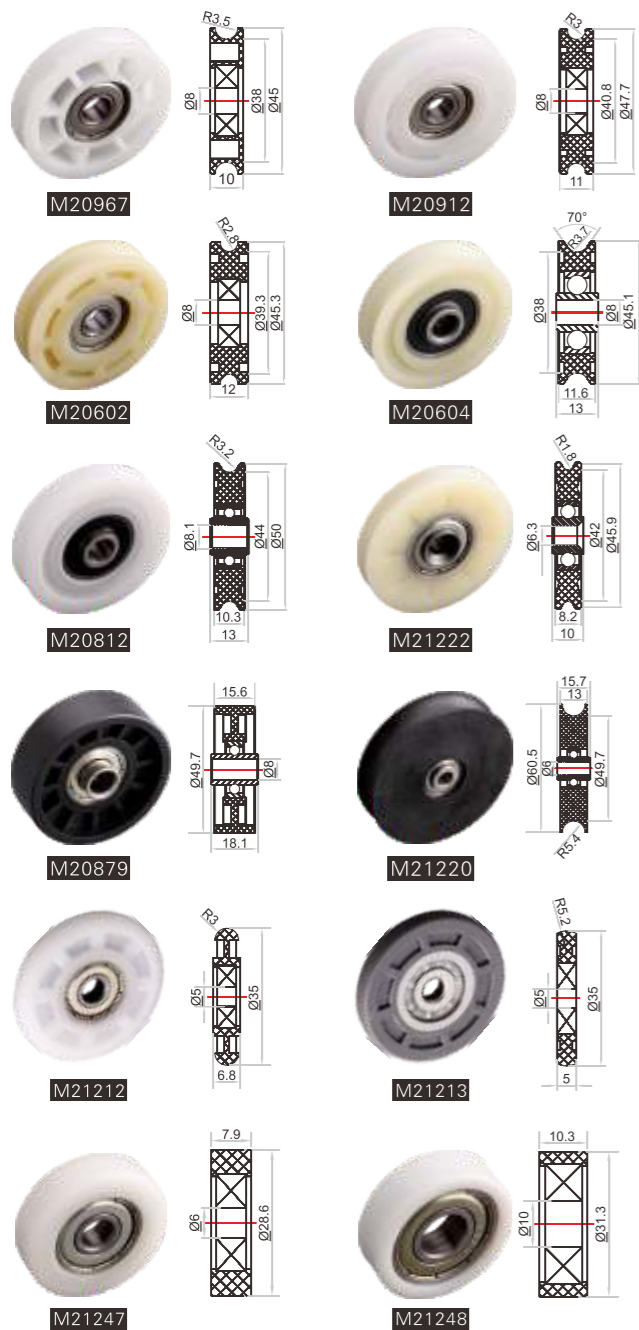

# M2 塑料滑轮 (磨加工) plastic pulley(ground)



# M2 塑料滑轮 (磨加工) plastic pulley(ground)

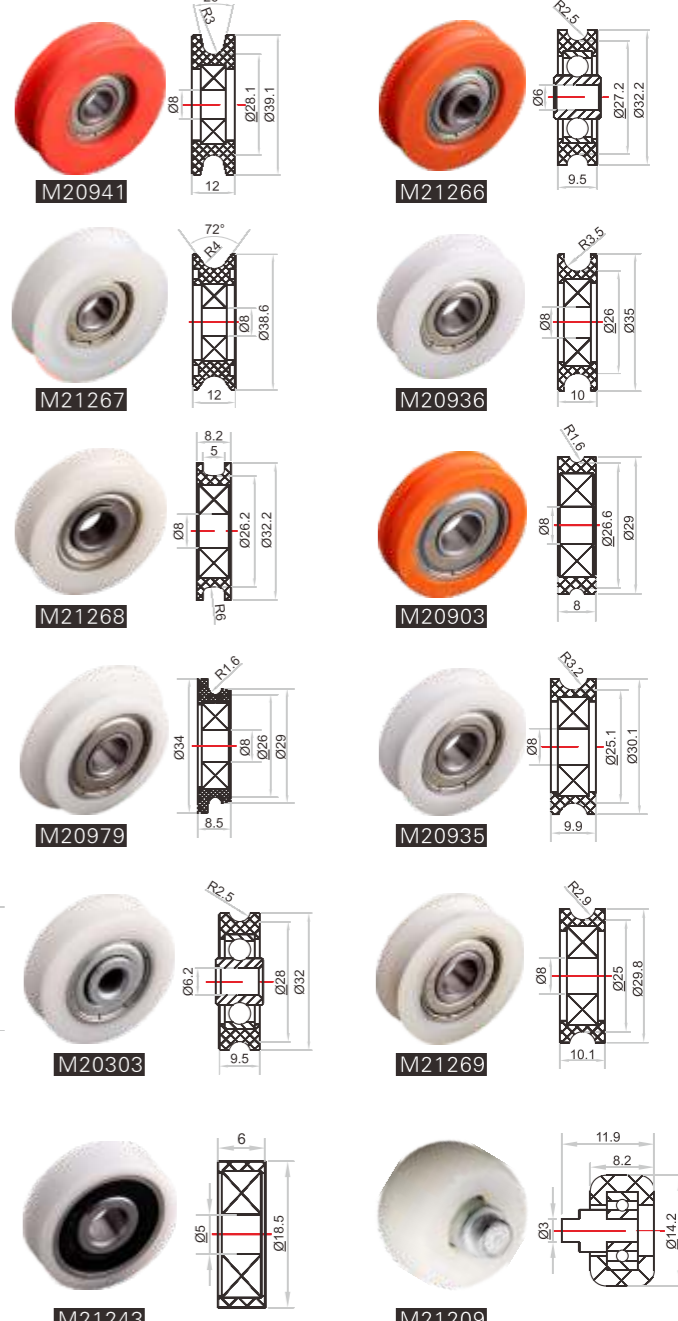
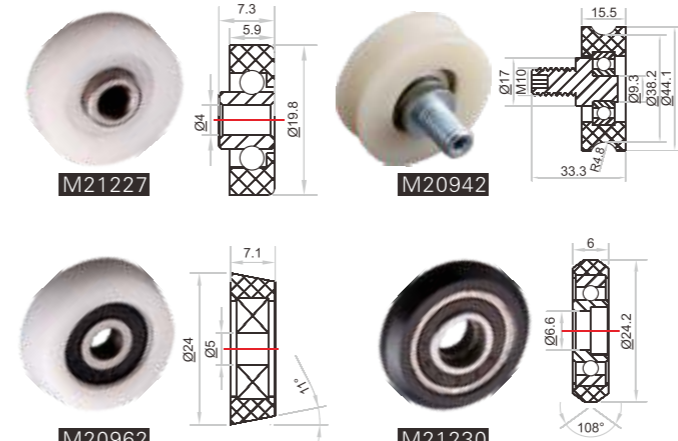
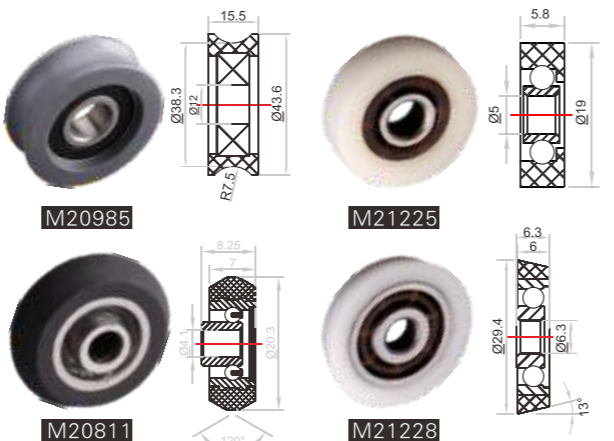
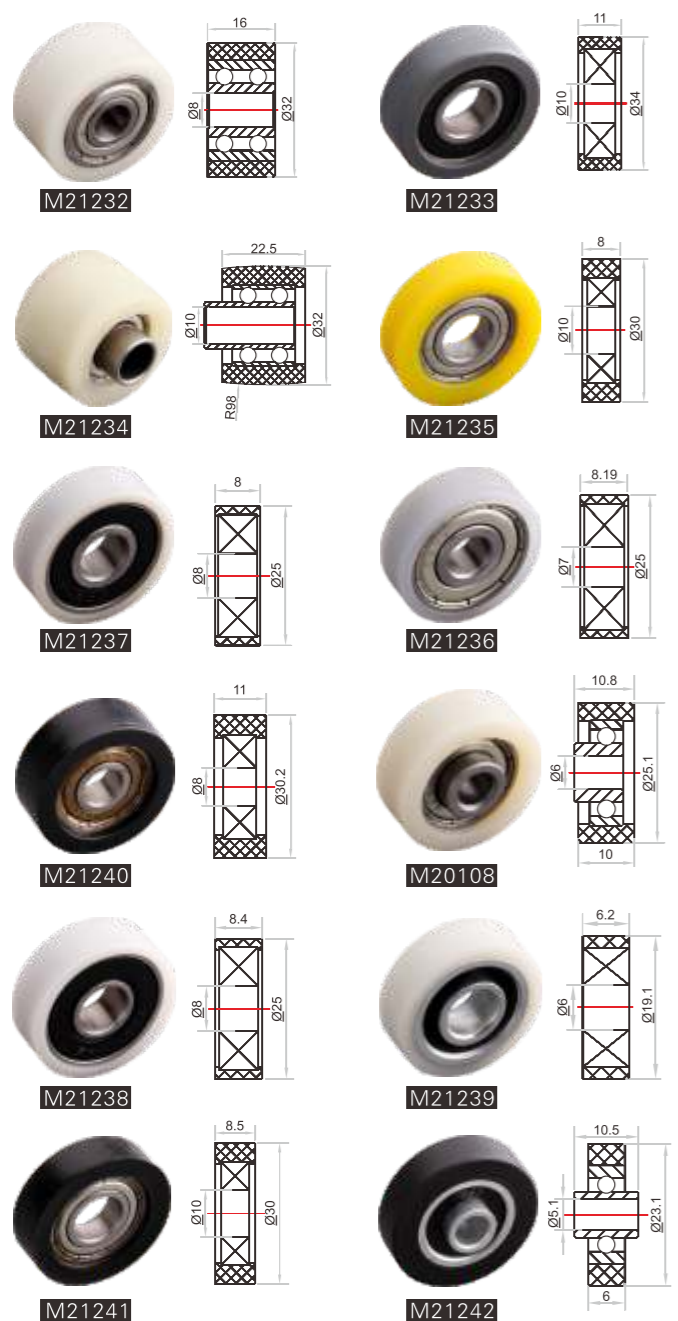
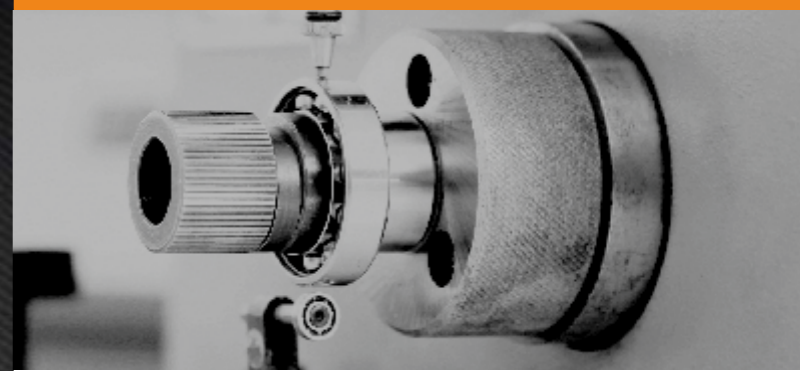

# M2 塑料滑轮 (磨加工)

plastic pulley(ground)



# M2 塑料滑轮 (磨加工)

plastic pulley(ground)

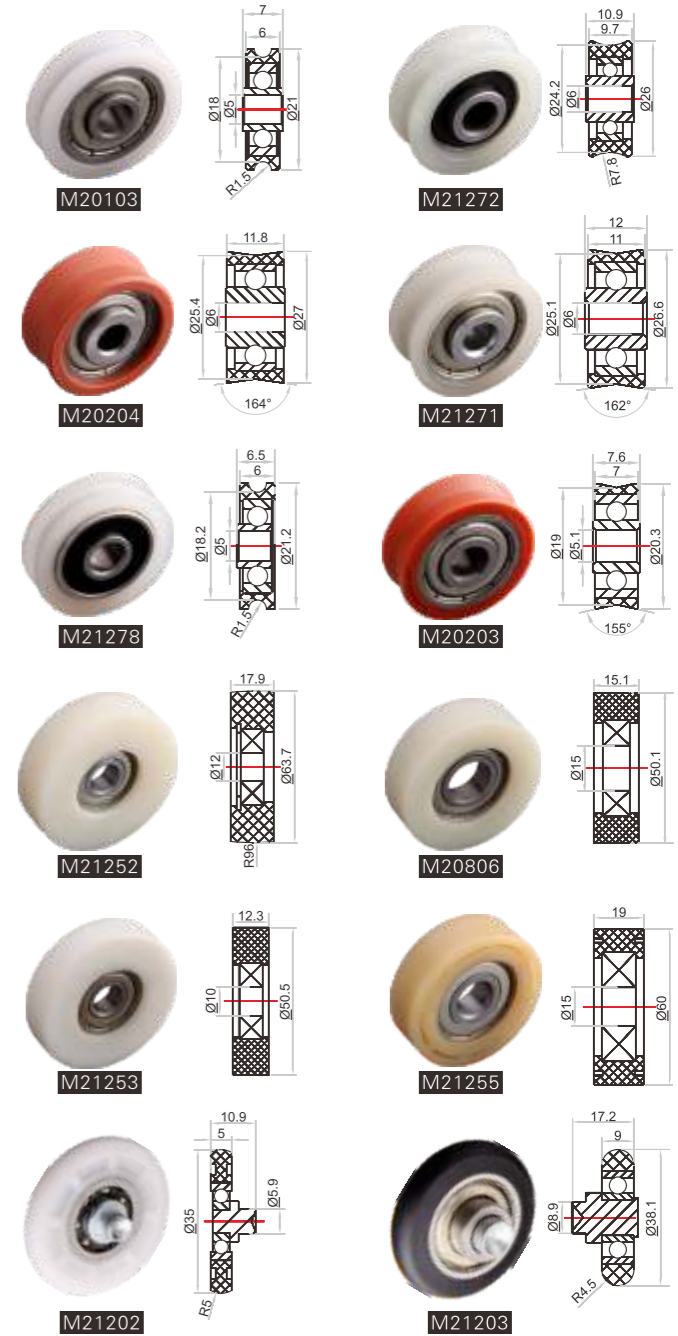
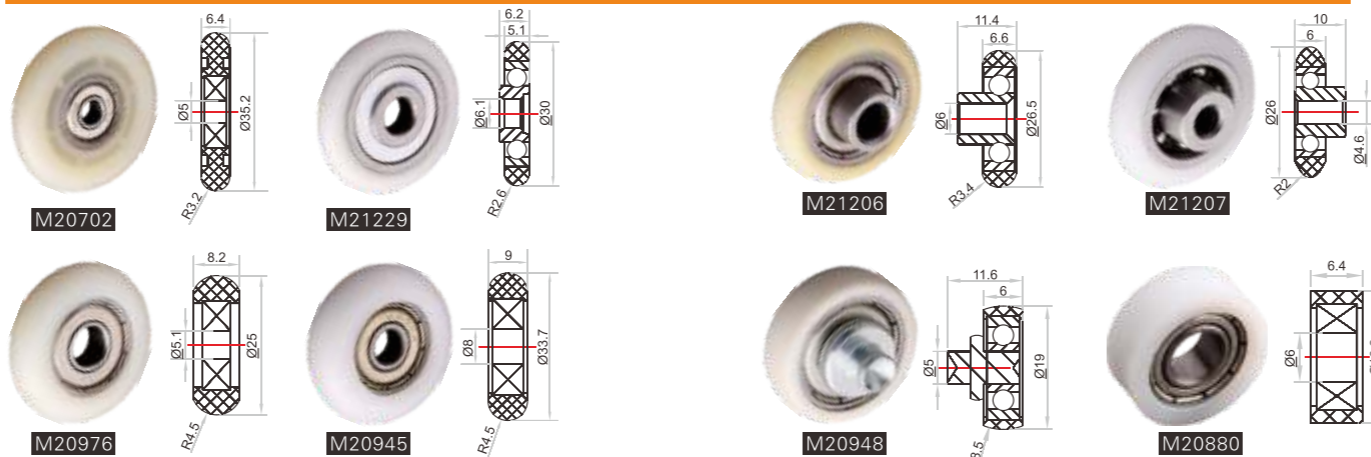
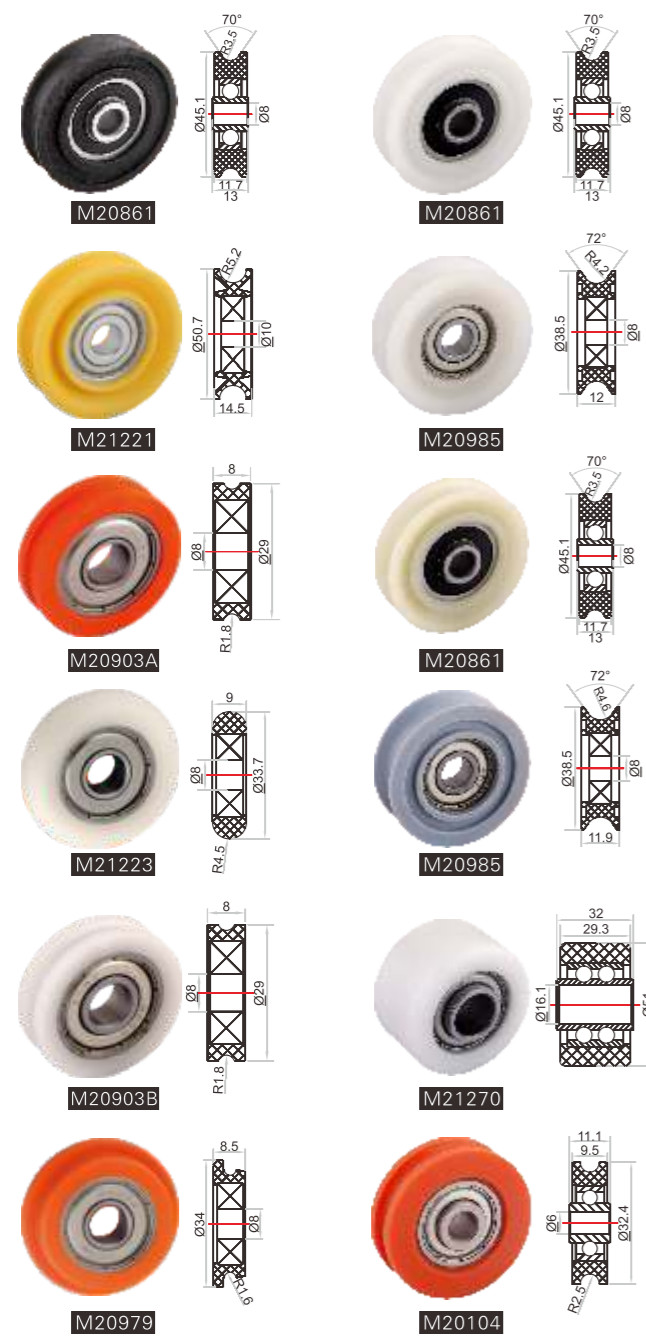

# M2 塑料滑轮 (磨加工)

plastic pulley (ground)



# M2 塑料滑轮 (磨加工)

plastic pulley (ground)

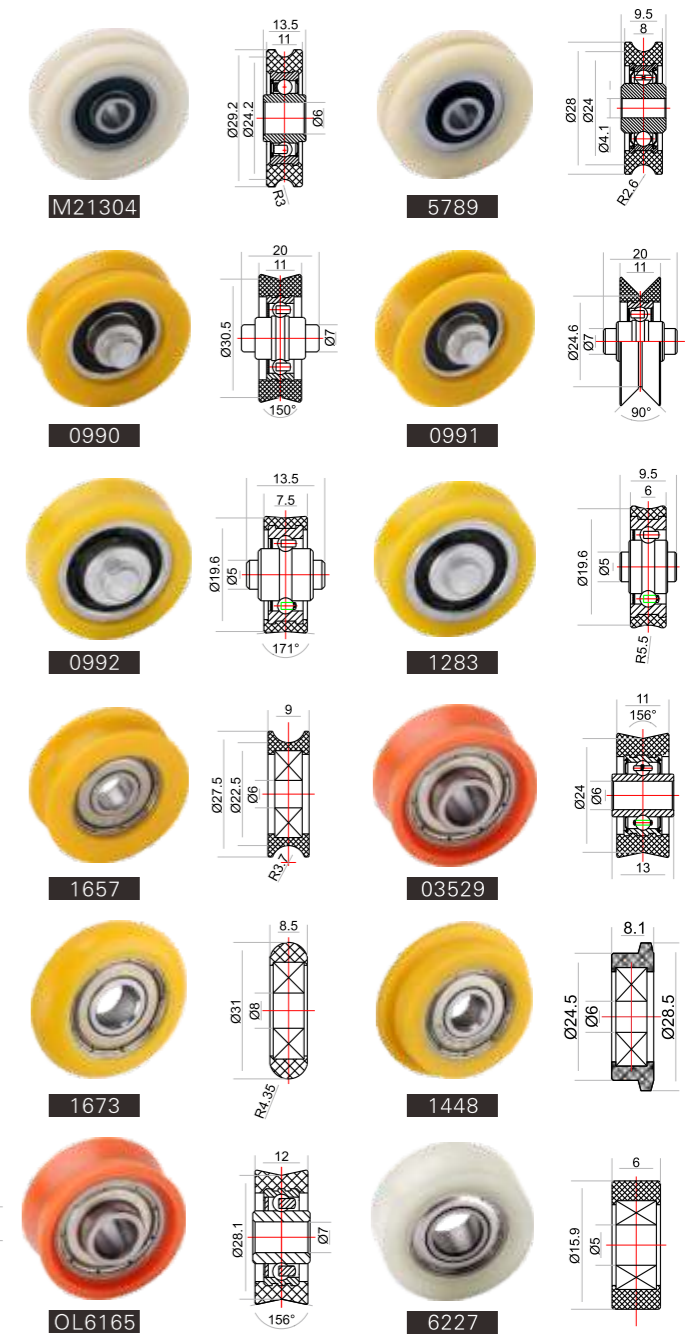
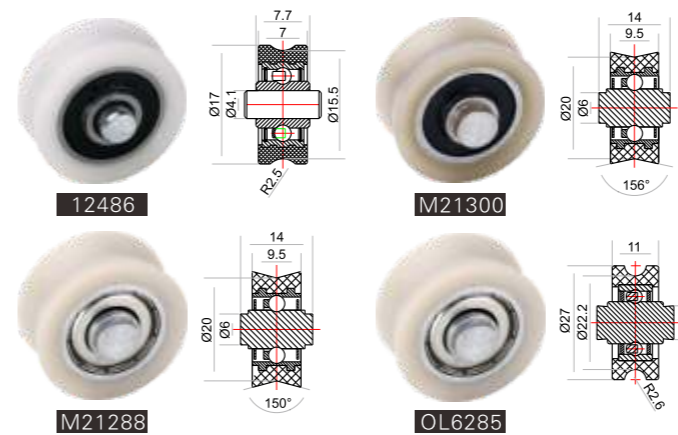
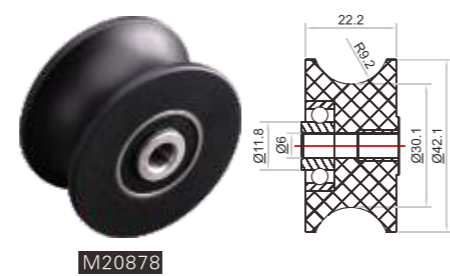
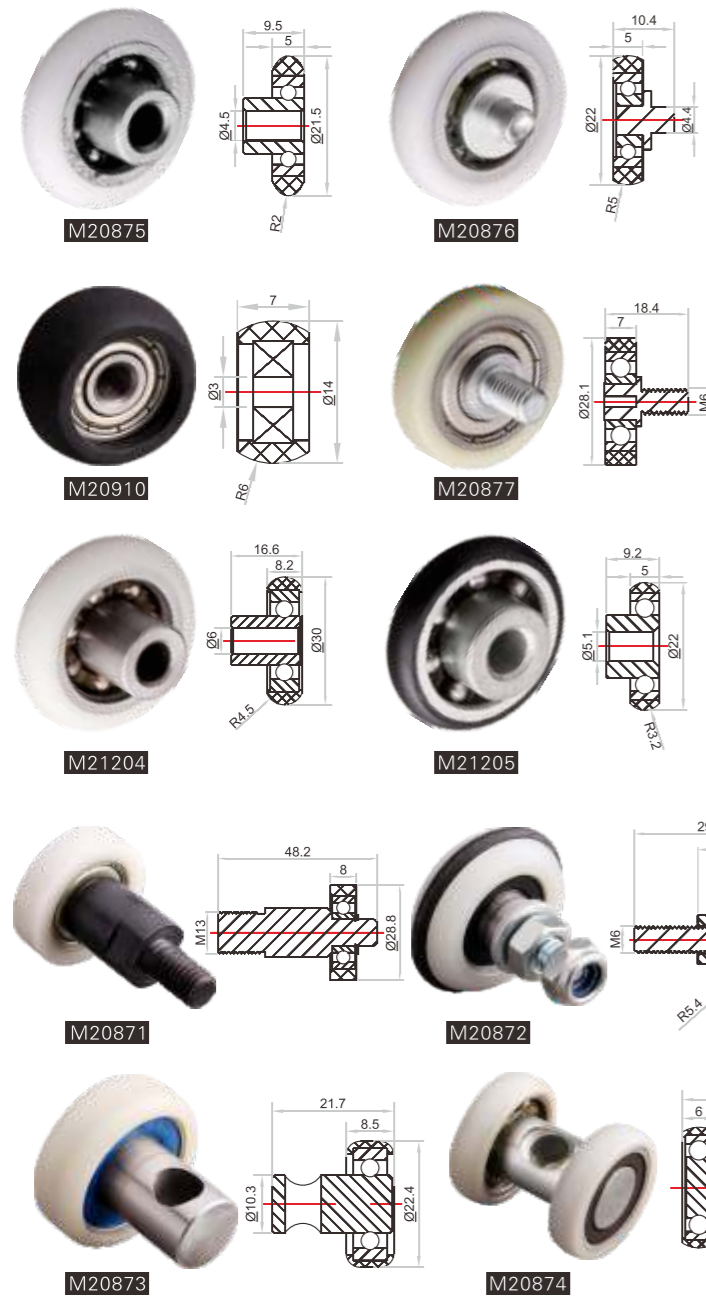

# M3 不锈钢滑轮(磨加工)

stainless steel pulley(ground)

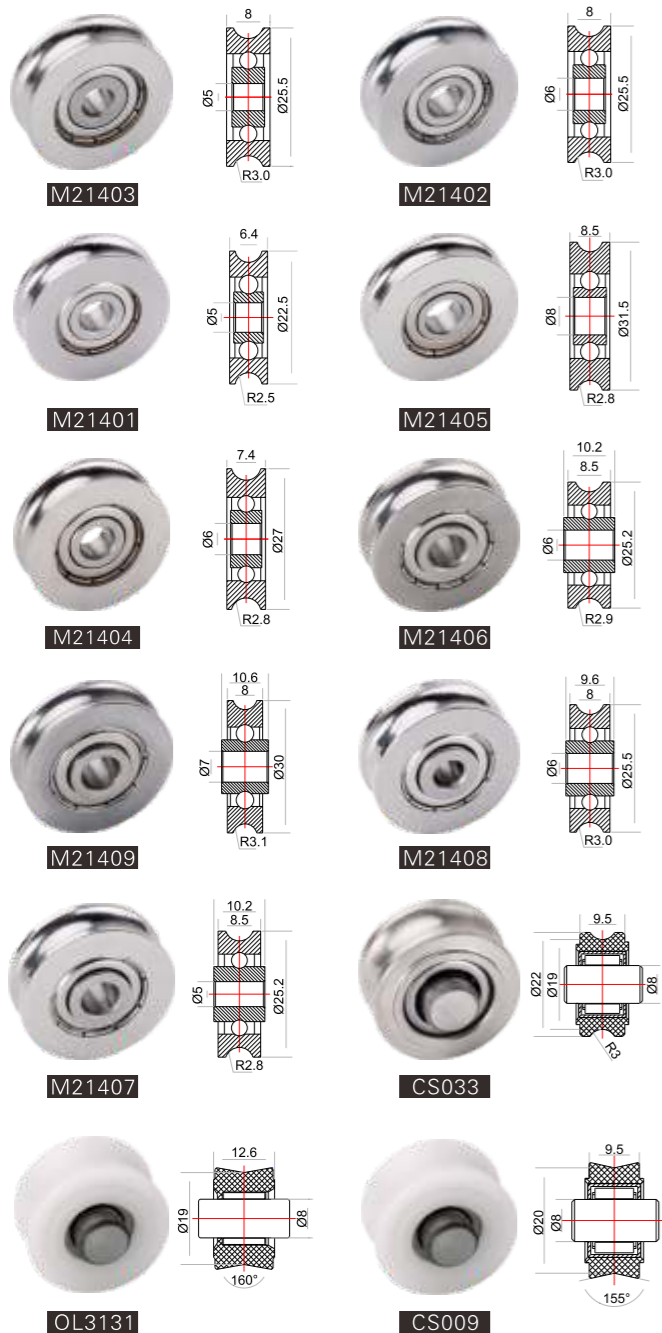

RIECHE  
SLIDING HARDWARE



RIECHE  
SLIDING HARDWARE



材质/Material  
不锈钢  
Stainless Steel  
运用领域/Application  
门窗五金  
Door and Window Hardware

材质/Material  
钢  
Steel  
运用领域/Application  
门窗五金  
Door and Window Hardware

# M3 非标轴承(车削轴承)

special bearing(turning)

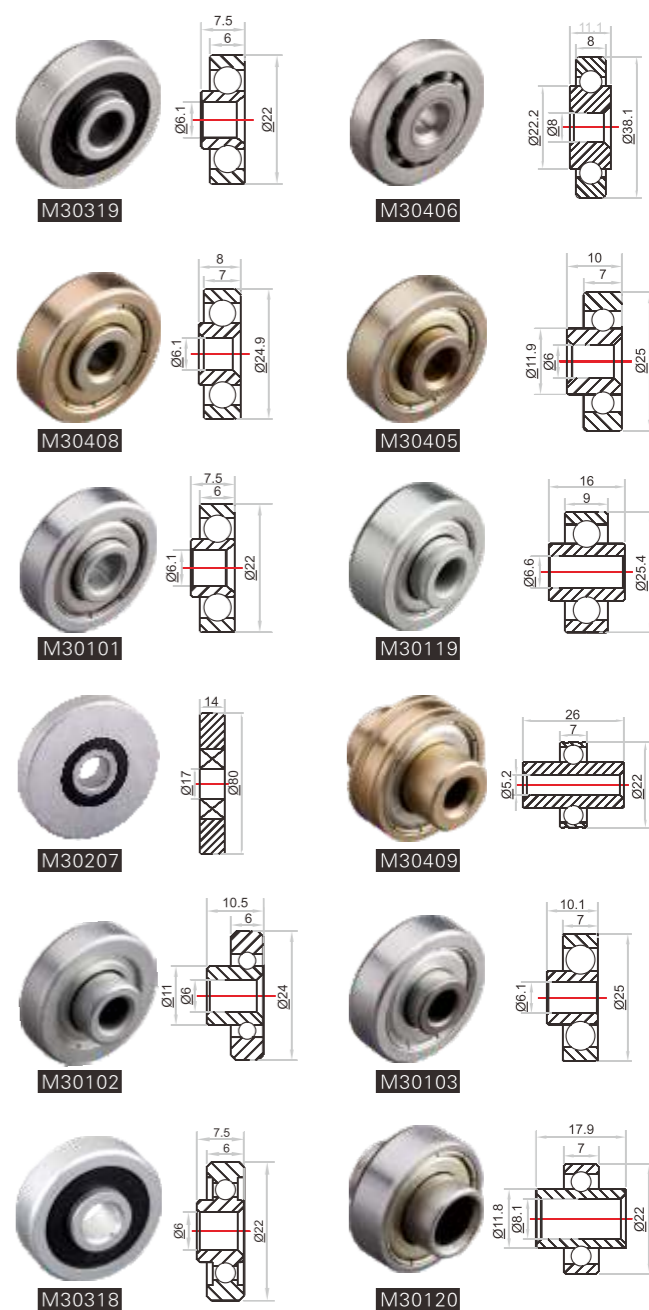

# M3 非标轴承(车削轴承)

special bearing(turning)



# M3 满球轴承

Full ball bearing

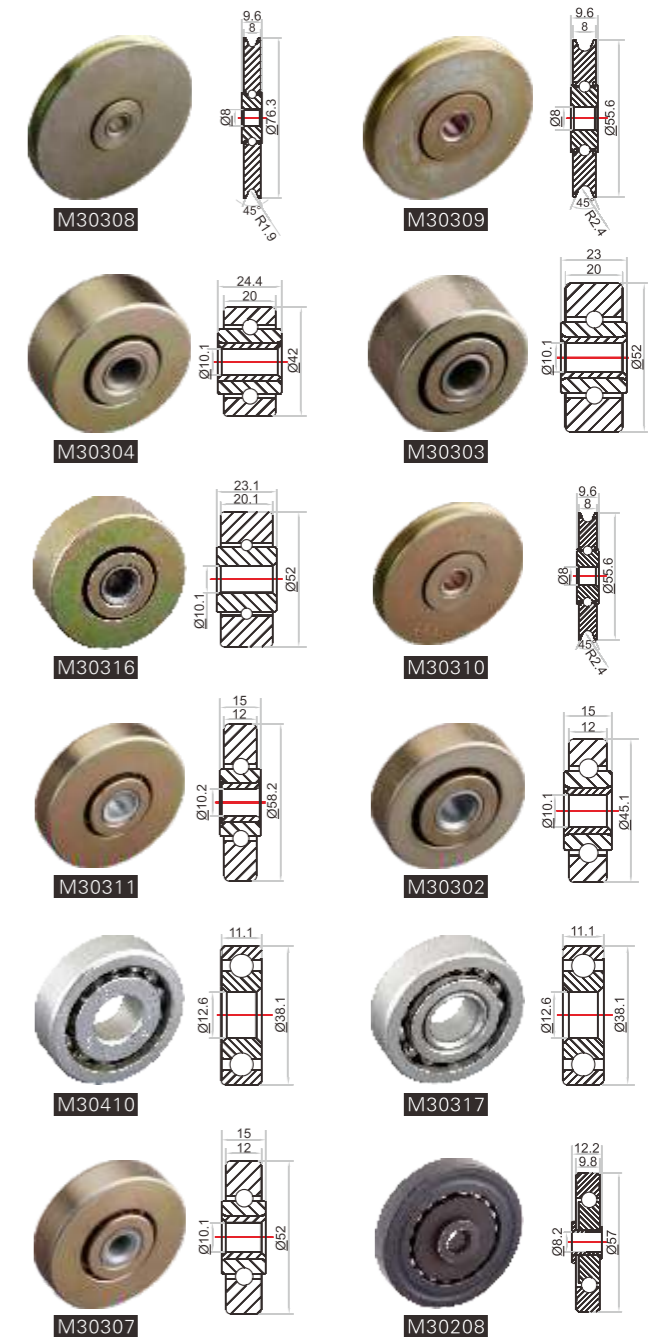
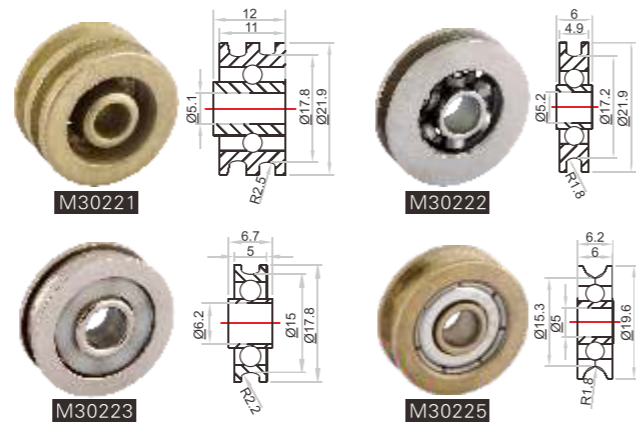
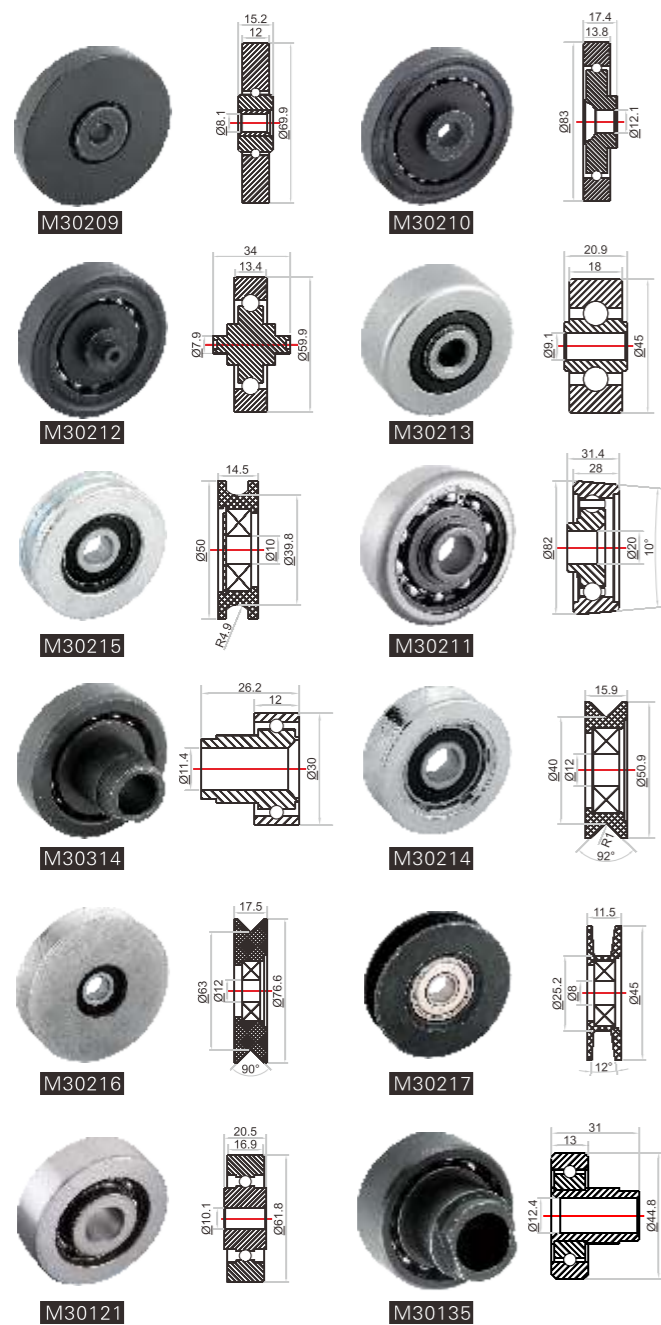

**材质/Material**  
 钢, 轴承钢  
 Steel, 100Cr6

**运用领域/Application**  
 门窗五金, 链条和物流等  
 Door and Window Hardware  
 Chain&Logistics

# M4 非标轴承(磨加工)

special bearing(ground)

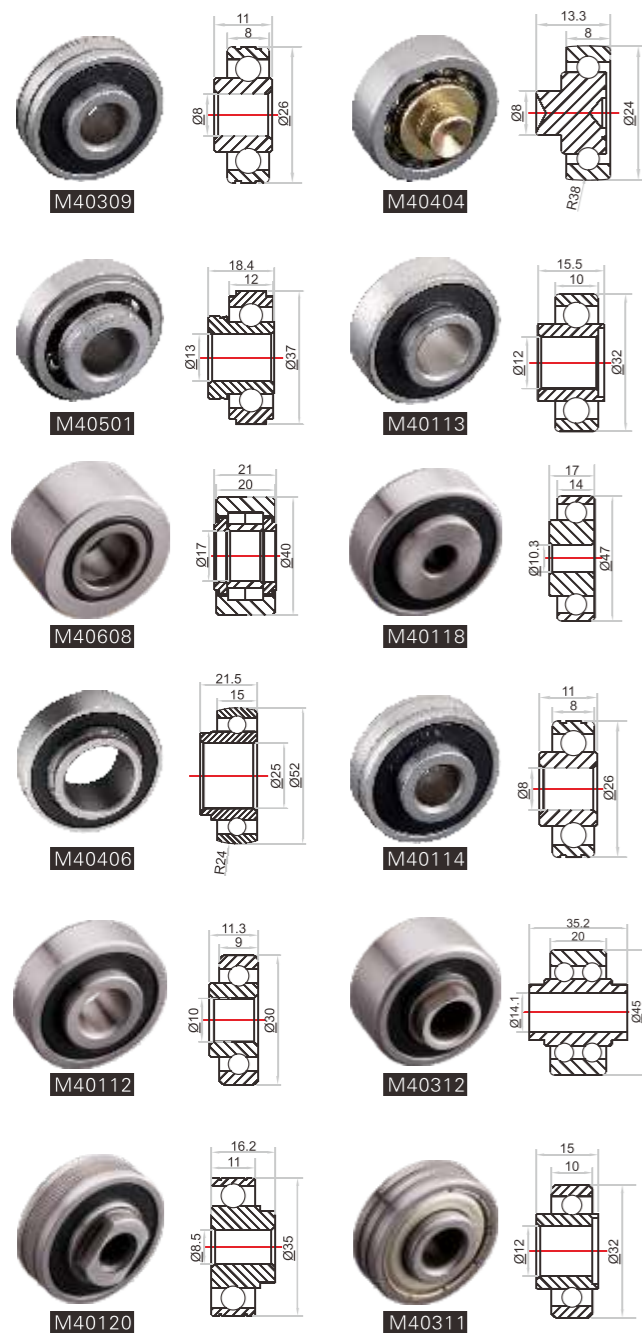

**材质/Material**  
 轴承钢, 不锈钢  
 100Cr6, Stainless Steel

**运用领域/Application**  
 机械传动  
 Mechanical Transmission

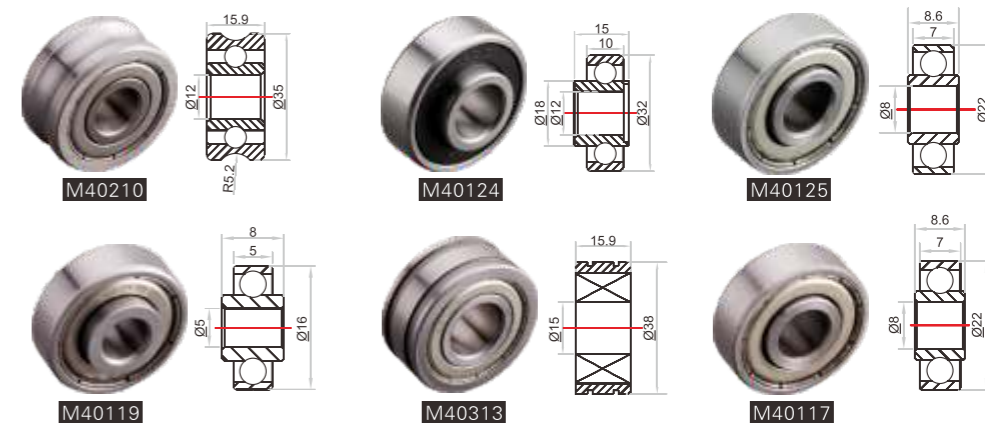

# M4 非标轴承(磨加工)

special bearing(ground)

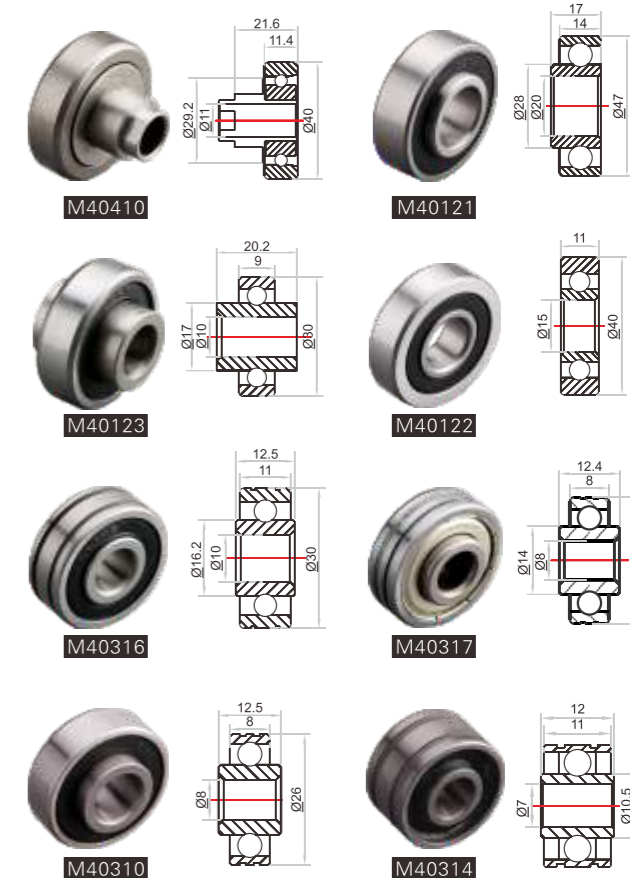

# M4 非标轴承(磨加工)

special bearing(ground)

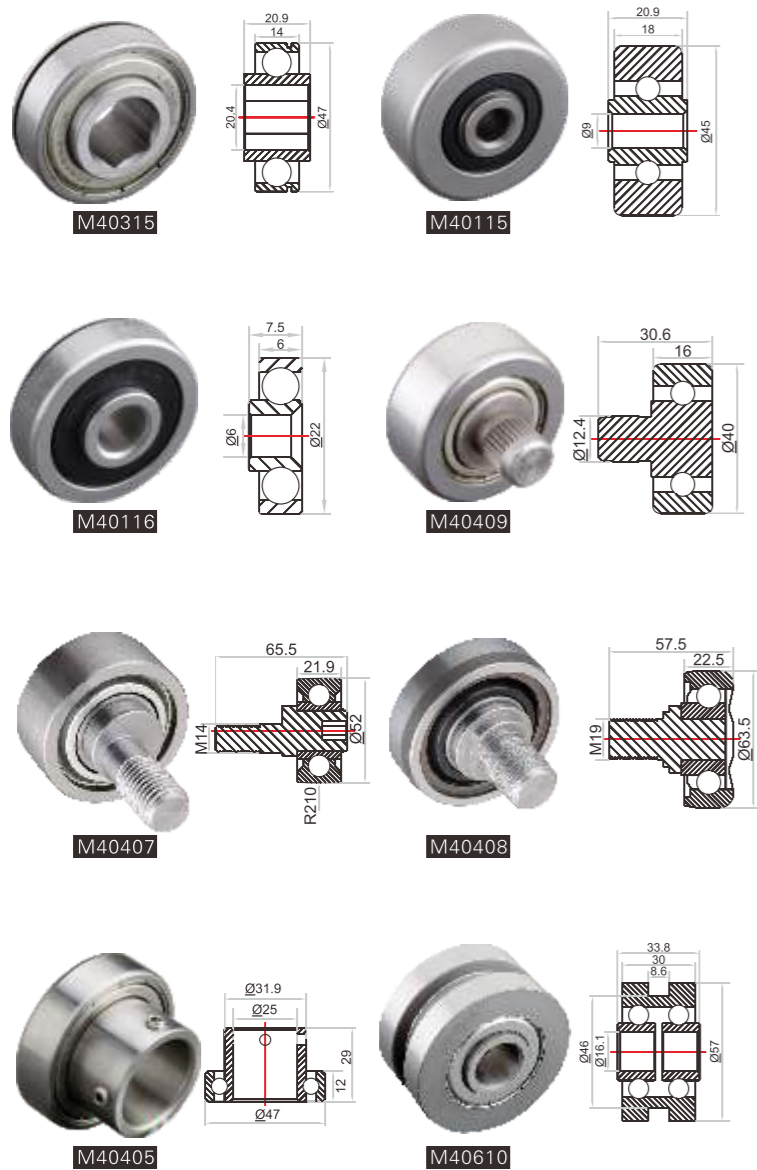

RIECHE  
SLIDING HARDWARE



RIECHE  
SLIDING HARDWARE



# M5 滑轮组

sliding roller&trolley



### 材质/Material

轴承钢, 不锈钢  
100Cr6, Stainless Steel

### 运用领域/Application

机械传动  
Mechanical Transmission

### 材质/Material

钢, 轴承钢, 冷轧板  
Steel, 100Cr6, SPCC

### 运用领域/Application

外门移动系统  
Outer Door Sliding System



# M5 吊门轮

Hanger wheel



RIECHE  
SLIDING HARDWARE

RIECHE  
SLIDING HARDWARE

# M6 冲压轴承

stamping bearing

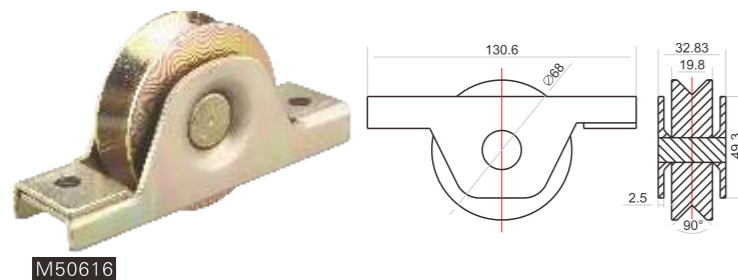
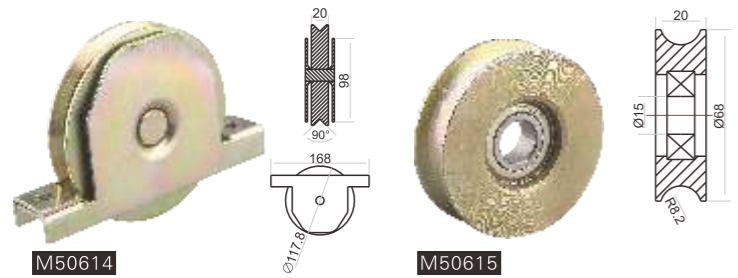
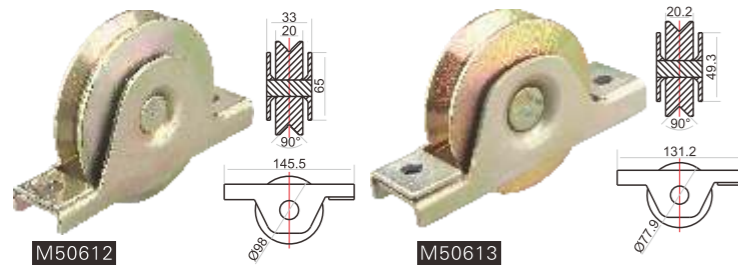
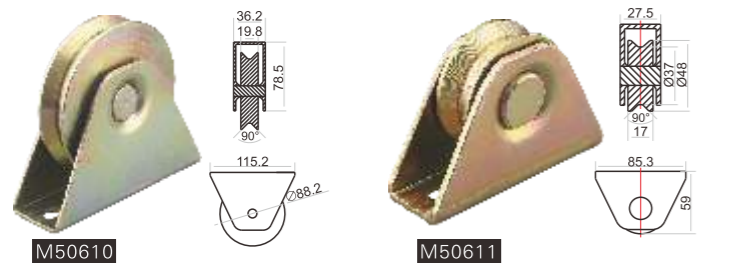
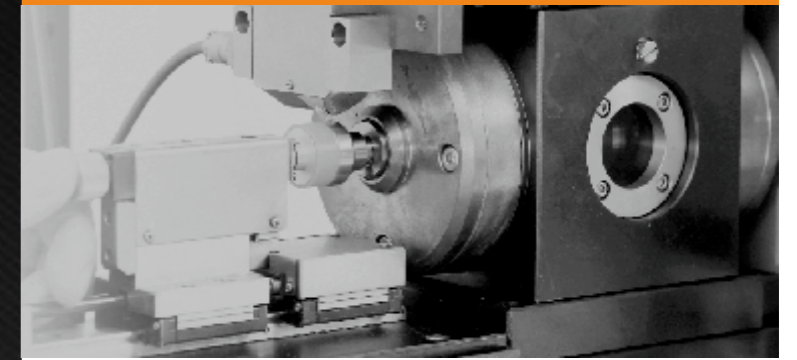

## 材质/Material

钢, 轴承钢, 冷轧板  
Steel, 100Cr6, SPCC

## 运用领域/Application

外门移动系统  
Outer Door Sliding System



## 材质/Material

冷轧板, 轴承钢  
SPCC, 100Cr6

## 运用领域/Application

物流, 滚筒  
Conveyor, Roller

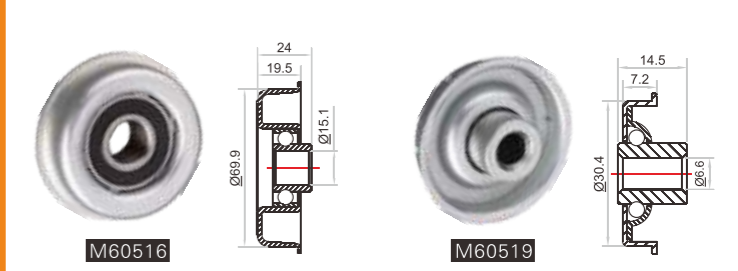
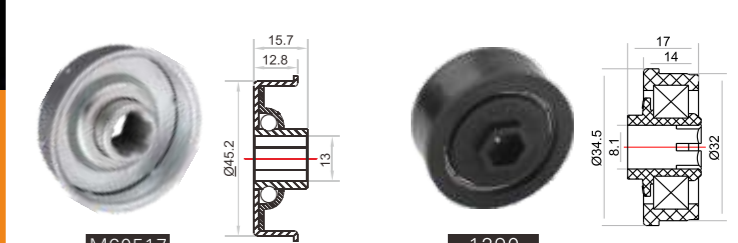
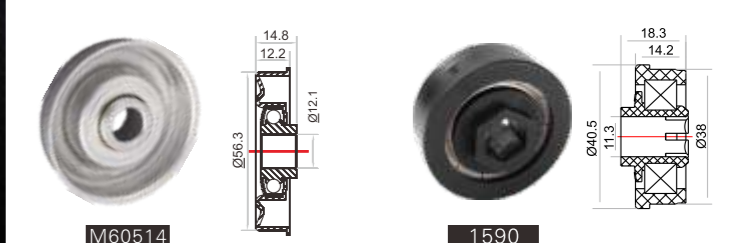
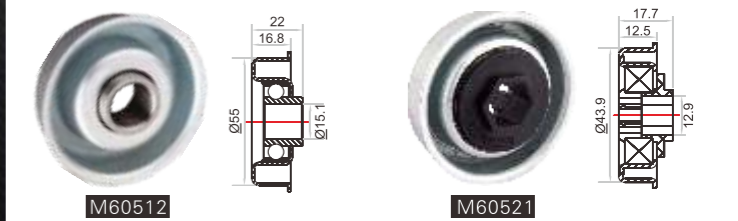
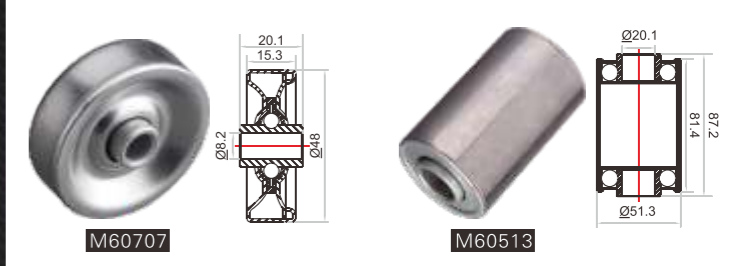

# M6 冲压轴承

stamping bearing



RIECHE  
SLIDING HARDWARE

RIECHE  
SLIDING HARDWARE

# M6 冲压轴承

stamping bearing

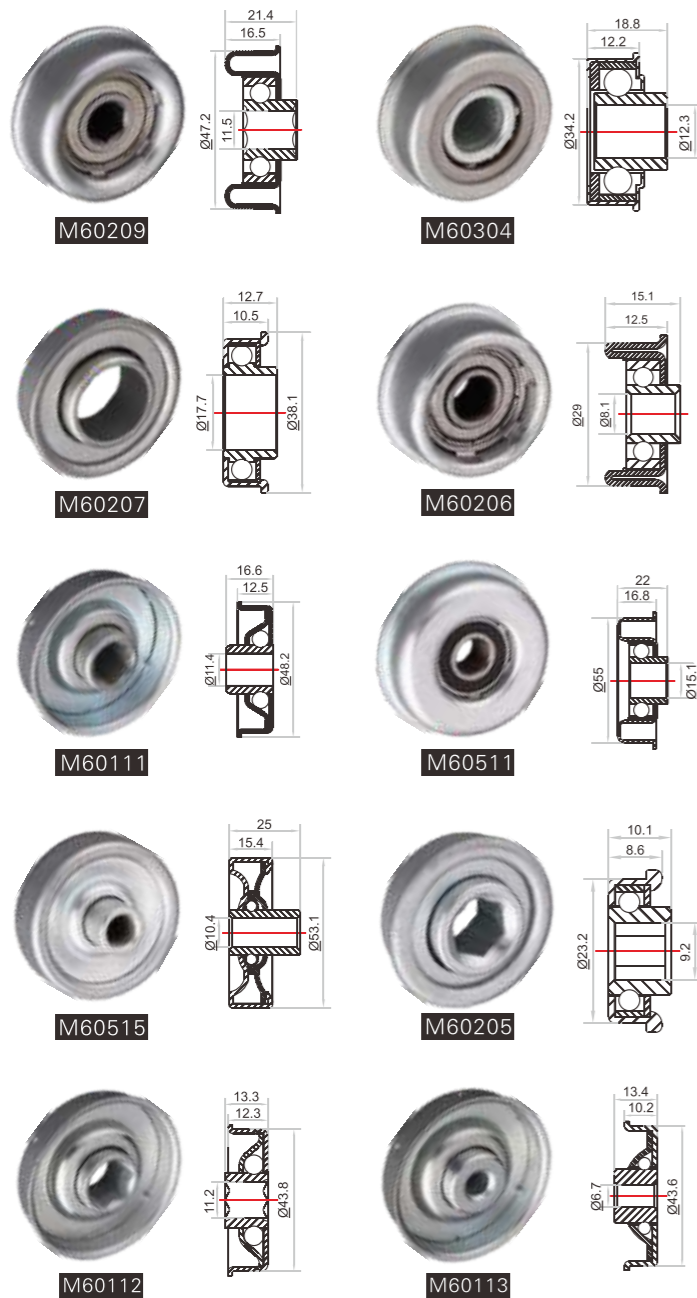

**材质/Material**  
冷轧板, 轴承钢  
SPCC, 100Cr6

**运用领域/Application**  
物流, 滚筒  
Conveyor, Roller

**材质/Material**  
冷轧板, 轴承钢  
SPCC, 100Cr6

**运用领域/Application**  
物流, 滚筒  
Conveyor, Roller

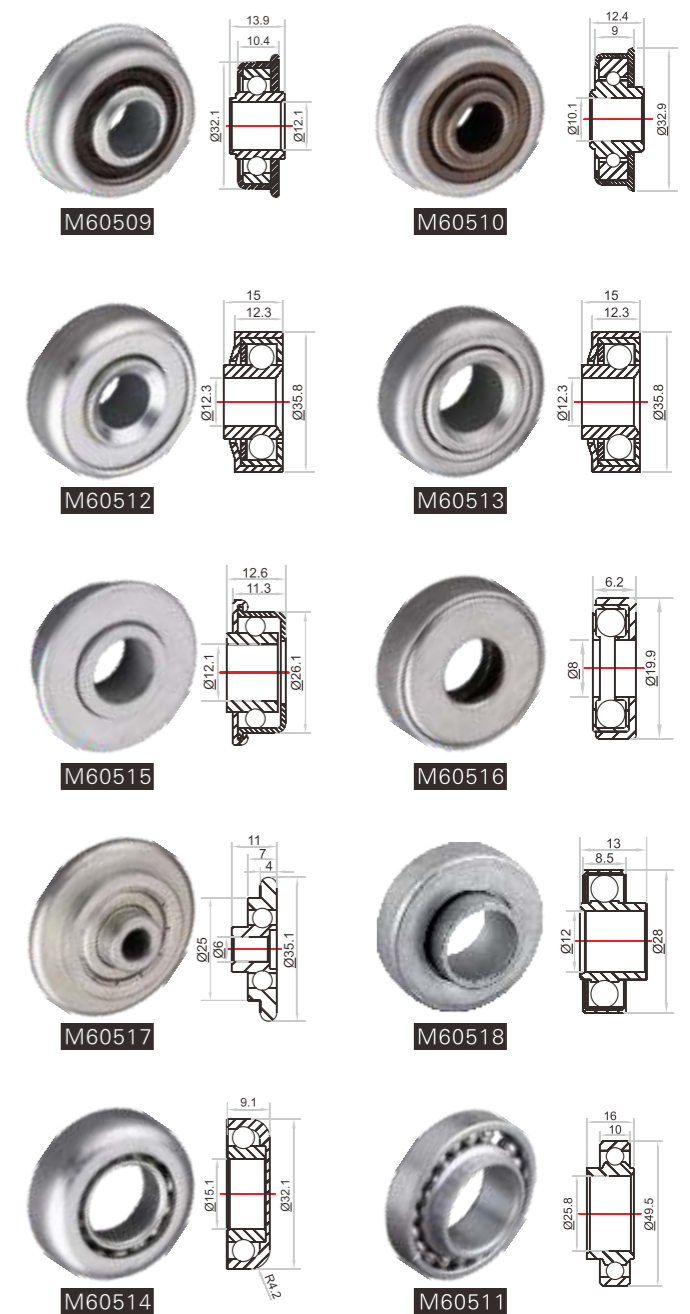

# M7 万向球

ball transfer unit



RIECHE  
SLIDING HARDWARE



RIECHE  
SLIDING HARDWARE



# M7 脚轮轴承

Castor Wheel Bearing

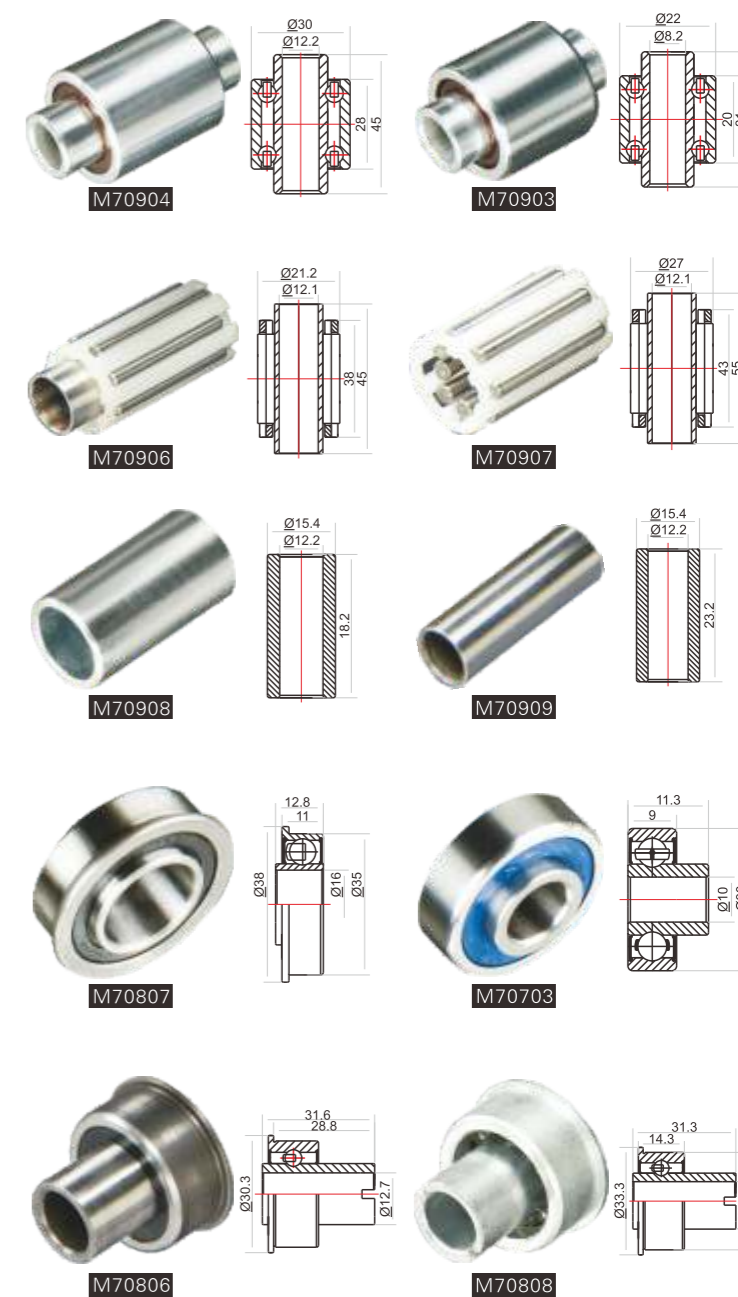

### 材质/Material

冷轧板, 不锈钢  
SPCC, Stainless Steel

### 运用领域/Application

物流  
Conveyor

### 材质/Material

聚甲醛, 尼龙66, 不锈钢, 轴承钢  
POM, PA66, Stainless Steel, 100Cr6

### 运用领域/Application

物流, 运输, 机械  
Logistics, Transport, Machinery

# M7 脚轮轴承

Castor Wheel Bearing



RIECHE  
SLIDING HARDWARE

RIECHE  
SLIDING HARDWARE

# M8 车库门轴承

garage door bearing

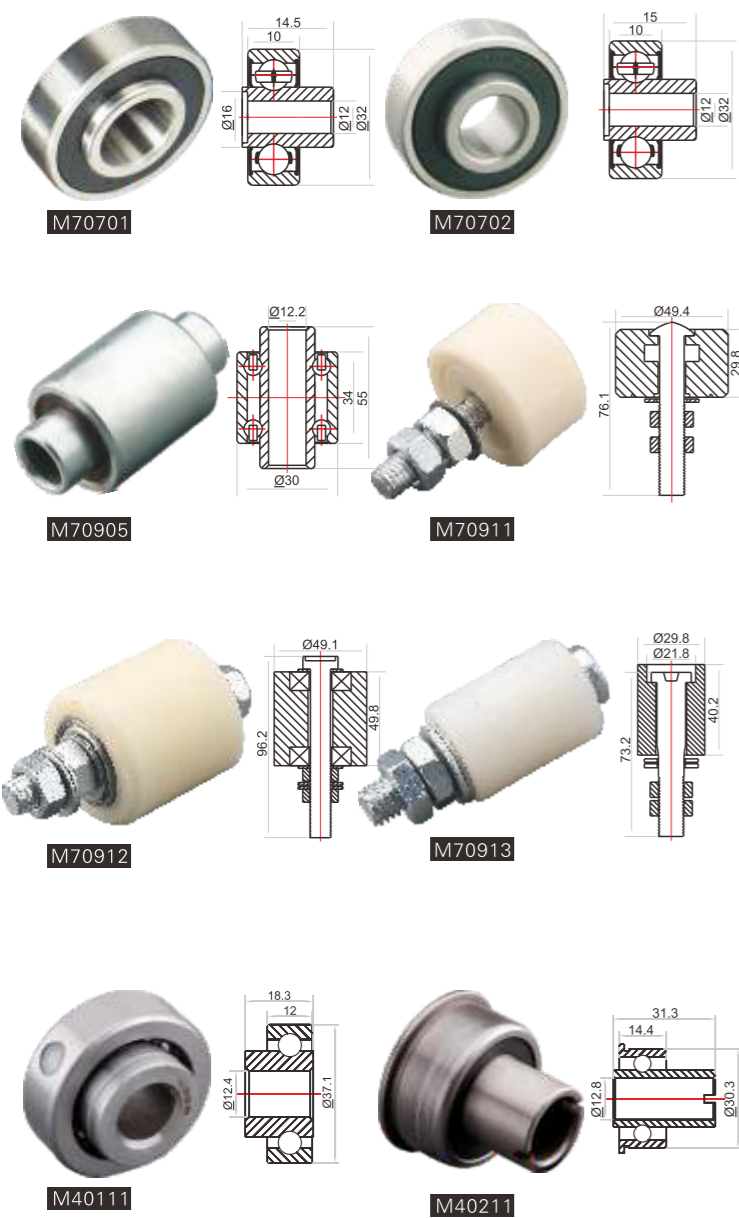

## 材质/Material

聚甲醛, 尼龙66, 轴承钢  
POM, PA66, 100Cr6

## 运用领域/Application

物流, 运输, 机械  
Logistics, Transport, Machinery



## 材质/Material

尼龙66, 冷轧板, 钢  
PA66, SPCC, 100Cr6

## 运用领域/Application

车库门  
garage door

# M9 聚氨酯滑轮

urethane pulley

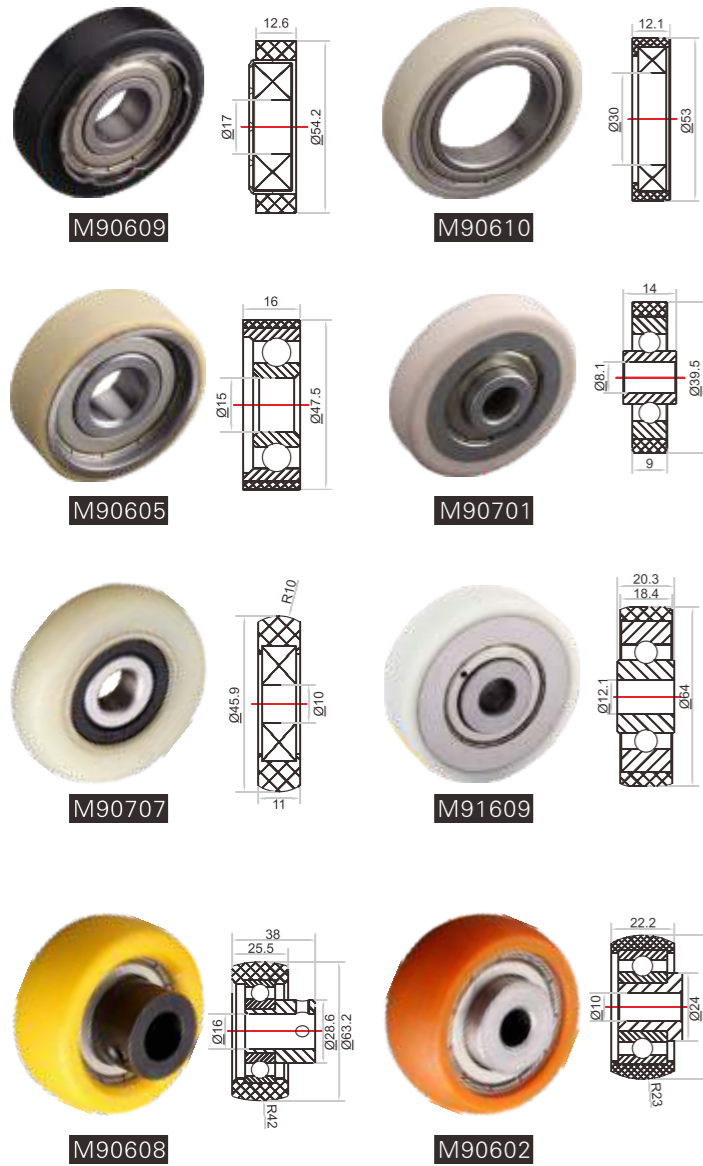

RIECHE  
SLIDING HARDWARE



## 材质/Material

聚氨酯, 轴承钢  
PU, 100Cr6

## 运用领域/Application

物流  
Conveyor

RIECHE  
SLIDING HARDWARE

# M9 移门滑轮

sliding pulley

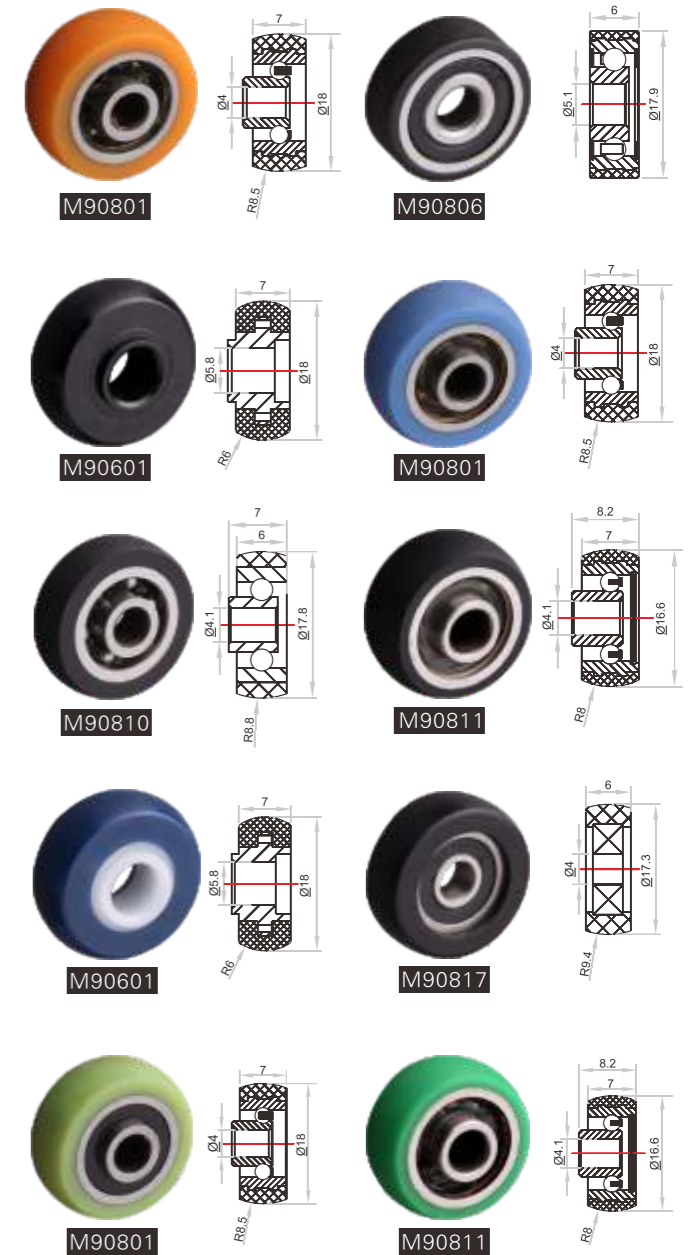

## 材质/Material

聚甲醛, 聚氨酯, 聚丙烯, 尼龙, 橡胶, 轴承钢  
POM, PU, PP, PA66, Rubber, 100Cr6

## 运用领域/Application

移门系统  
Sliding Door System

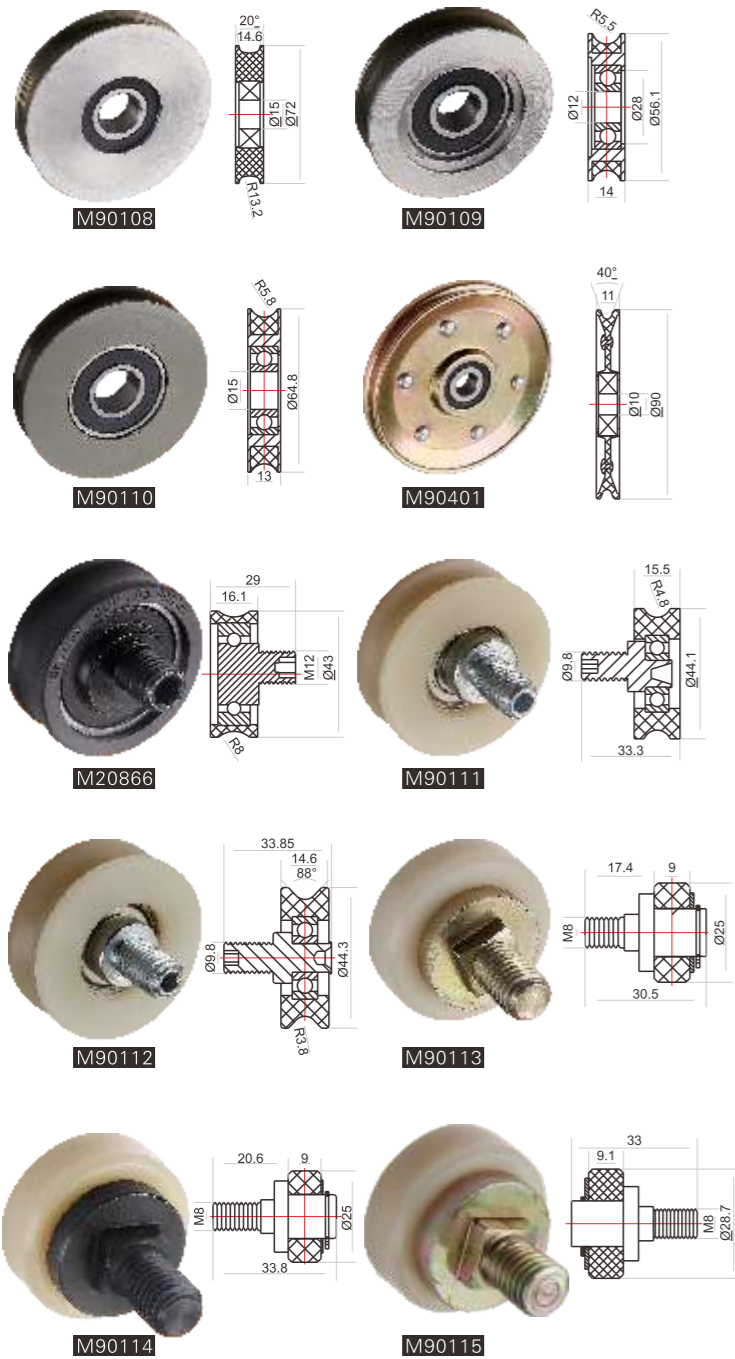
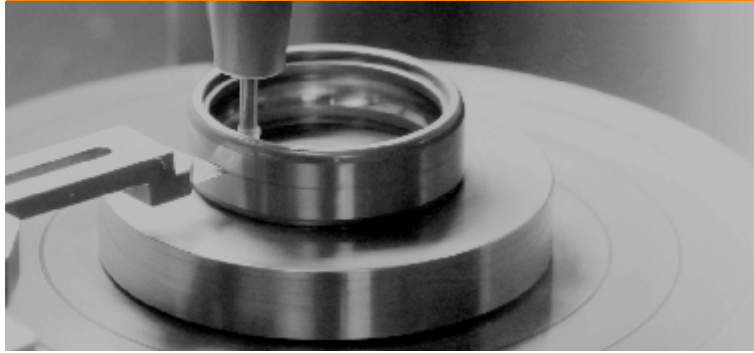

**材质/Material**  
 尼龙66, 轴承钢, 冷轧板  
 PA66, 100Cr6, SPCC  
**运用领域/Application**  
 电梯移门  
 Elevator Door

**材质/Material**  
 尼龙, 轴承钢, 冷轧板  
 PA66, 100Cr6, SPCC  
**运用领域/Application**  
 电梯移门  
 Elevator Door

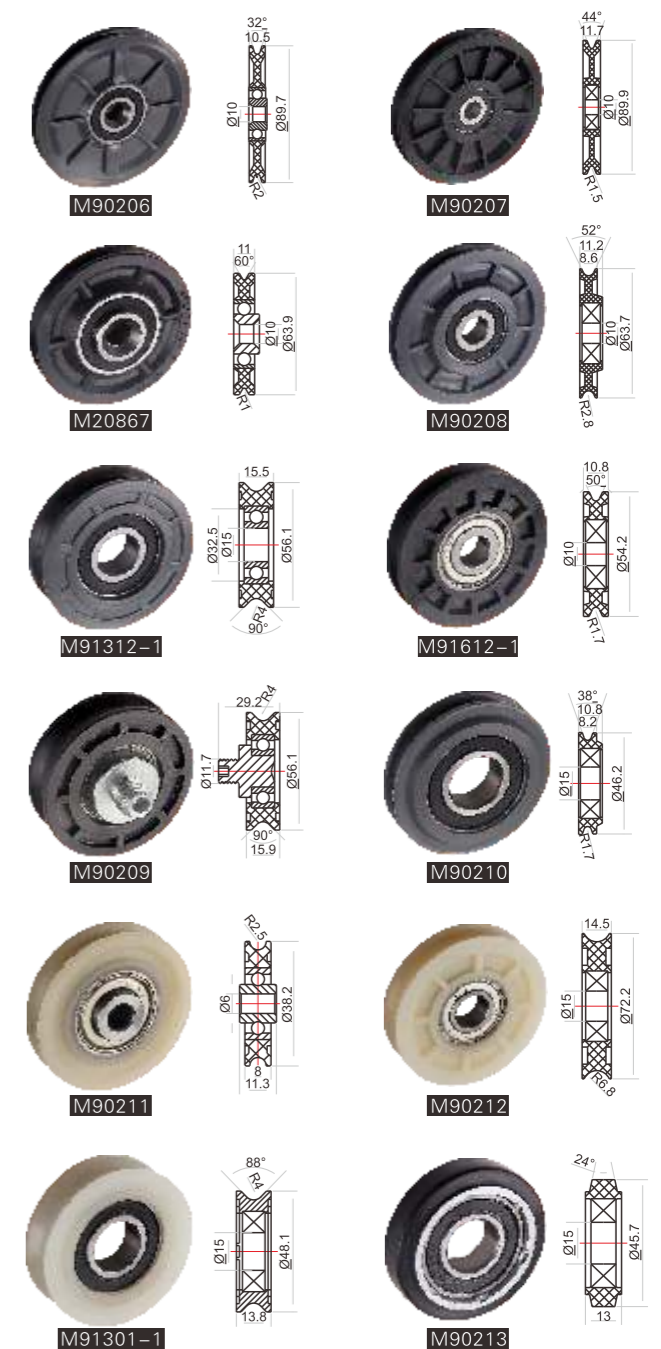

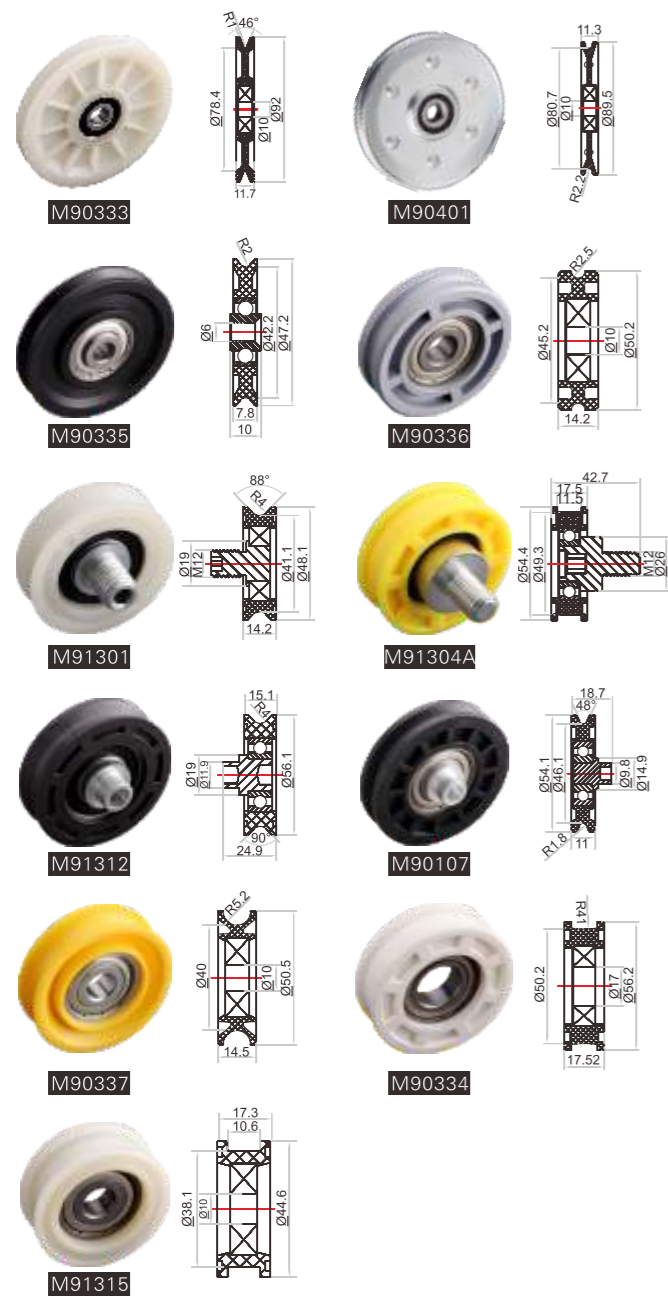

**材质/Material**  
 尼龙66, 轴承钢, 冷轧板  
 PA66, 100Cr6, SPCC  
**运用领域/Application**  
 电梯移门  
 Elevator Door

**材质/Material**  
 尼龙66, 冷轧板  
 PA66, SPCC  
**运用领域/Application**  
 电梯移门  
 Elevator Door

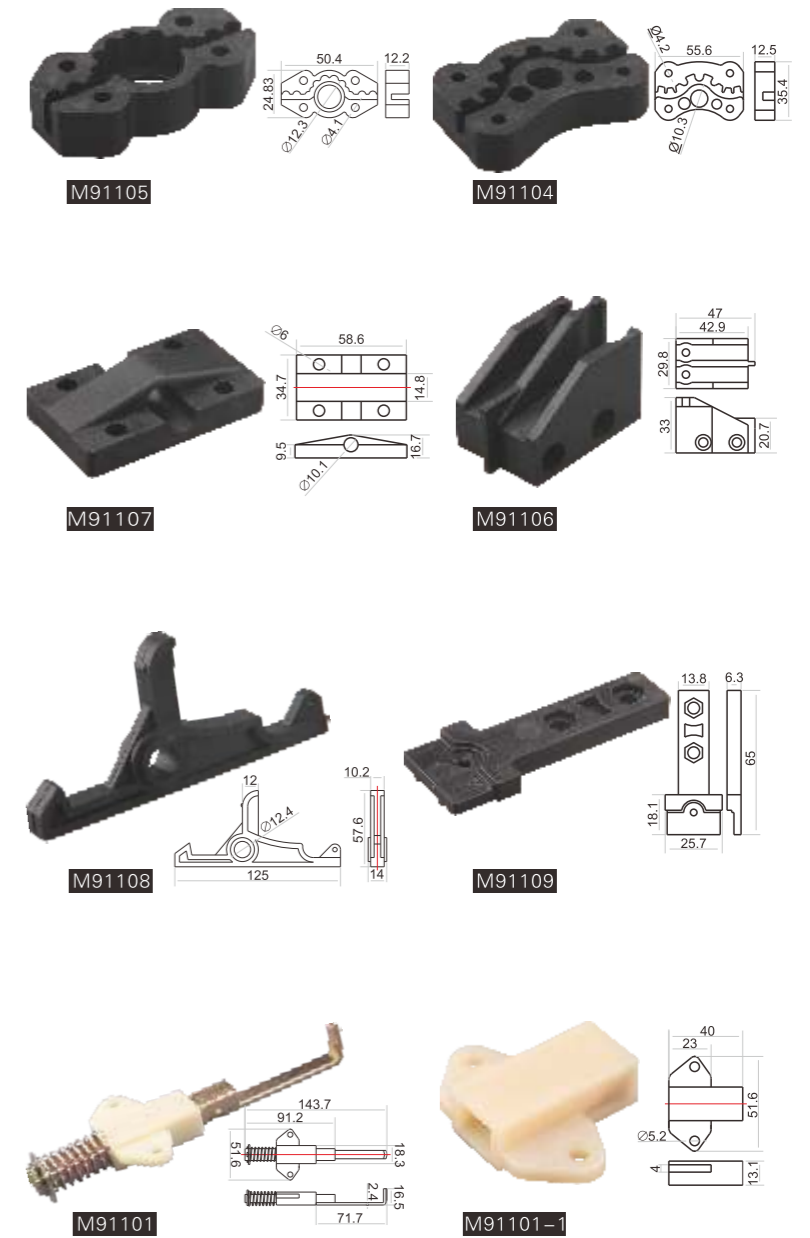

**外球面轴承**  
Spherical Bearings



UCF206

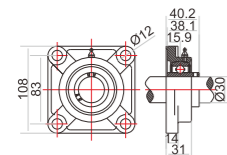

UCF207

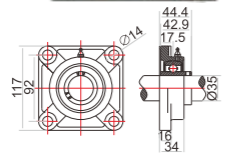

UCFL206

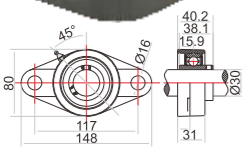

UCFL207

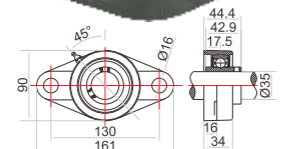

BS350

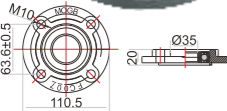

BS35A



UCP206

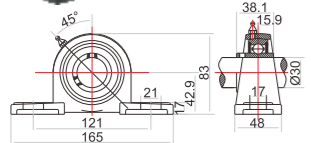

UCP207

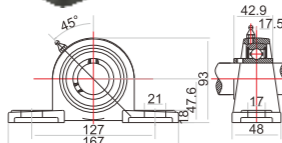

**RIECHE**  
SLIDING HARDWARE



**RIECHE**  
SLIDING HARDWARE



**M5 阻尼器**  
Damper



M50832



M50853



M50804



M50812



M50858



M50859



**材质/Material**  
铸铁, 轴承钢  
Cast Iron, 100Cr6  
**运用领域/Application**  
物流, 运输, 机械  
Logistics, Transport, Machinery

**材质/Material**  
尼龙66, 聚甲醛, 聚丙烯, ABS, 冷轧板  
PA66, POM, PP, ABS, SPCC  
**运用领域/Application**  
移门系统  
Sliding Door System